

prostoria

prostoria

CONTENT / SADRŽAJ

- 05 *prostor*a - Innovation as social responsibility /
Inovativnost kao društvena odgovornost**
- 18 CHAIRS / EASY CHAIRS / TABLES / SMALL TABLES
STOLICE / FOTELJE / STOLOVI / STOLIĆI**
- 92 SOFAS / SOFABEDS / ACCESSORIES
SOFE / SOFE NA RAZVLAČENJE / DODACI**
- 216 BIOGRAPHY
BIOGRAFIJA**

prostoria - Innovation
as social responsibility
/ Inovativnost kao
društvena odgovornost

MAROJE MRDULJAŠ



We tend to perceive furniture as something abstract, created on designers' desks and then produced, branded and placed on the market by companies with different statuses and reputations. In fact, relations inside the contemporary globalized furniture industry are becoming more and more fragmented with less and less opportunity for complete dedication to synergies and collaborations... **prostorja**, as a young company whose catalogue already comprises some new icons such as the *Polygon* armchair and the *Revolve* transformable sofa, stands as an example of a different and more traditional approach based on the evolution from the local givenness and logical clustering of all actors involved in the production process.



POLYGON

Navikli smo promatrati namještaj kao svojevrsnu apstrakciju osmišljenu na stolovima dizajnera koje zatim tvrtke različitih statusa i ugleda proizvode, brendiraju i plasiraju na tržište. Odistu, u suvremenoj globaliziranoj industriji namještaja odnosi su sve više odijeljeni i sve je manje prilike za potpuno posvećenje sinergijama i suradnjama... **prostorja**, mlada tvrtka koja u svom katalogu već ima nove ikone poput fotelje *Polygon* ili transformabilne sofe *Revolve*, primjer je drugačijega, uvjetno rečeno tradicionalnijeg pristupa, zasnovanog na izrastanju iz lokalnih datosti i logičnog povezivanja svih aktera u procesu proizvodnje.

Rapid development of **prostor**, formerly known as *Kvadra*, a company which has come a long way, from 'starting from zero' to positioning itself as the leader and promoter of new ideas in only a few years time, is a story about the reintroduction of continuity both in Croatia and Central Europe, a region with vital but insufficiently recognized design scene and remarkable tradition and knowledge of the furniture industry. Those elements served as latent potentials that provided grounds for continuation and had to be activated. Since the beginning, **prostor** has been developing an integrative approach, functioning as a collaboration platform that nourishes and stimulates continuous exchange of knowledge and experience between all the actors participating in the production of furniture.



REVOLVE

Brzi razvoj **prostor** (nekada Kvadre), koja je u svega par godina ostvarila put od «početka od nule» do pozicije lidera i promotora novih ideja, priča je i o ponovnom uspostavljanju kontinuiteta u Hrvatskoj i Centralnoj Europi, regiji s vitalnom, no nedovoljno prepoznatom dizajnerskom scenom i sa značajnom tradicijom i znanjem u industriji namještaja. To su bili latentni potencijali na koje se moglo nastaviti i koje je trebalo aktivirati. Od svojih početaka, **prostor** razvija integrativni pristup i funkcionira kao suradnička platforma koja njeguje i potiče kontinuiranu razmjenu znanja i iskustava između svih sudionika u proizvodnji namještaja.





A dynamic workshop ambience has been created offering opportunities mainly to young designers to explore their ideas in excellent conditions and bring them to the highest level of design, functionality and technological artisanship. Many products have been developed over longer periods of time surpassing a number of iterations until reaching their final form, which would be impossible without the adequate support combining the contemporary technology and meticulous craftsmanship and handwork of the highest quality. Predominantly local materials are used, especially solid wood, and most of the production takes place within the company itself.



Stvoren je dinamični, radionički ambijent koji je mahom mladim dizajnerima pružio priliku da u izvrsnim uvjetima istraže svoje ideje i dovedu ih do najviše razine oblikovne, funkcionalne i tehnološke doradenosti. Mnogi proizvodi razvijani su dugoročno i prošli su više iteracija do konačne forme, što ne bi bilo moguće bez odgovarajuće podrške gdje se kombiniraju suvremena tehnologija i minuciozni, obrtnički i ručni rad najviše kvalitete. Uglavnom se koriste lokalni materijali, naročito masivno drvo, a većina proizvodnje odvija se unutar same tvrtke.

RHOMB

While the company's catalogue also offers furniture based on already proven models, **prostor** shows strategic and even passionate dedication to research-based design, convinced that authenticity has its place on the market but presents a special challenge in the times when it seems almost impossible to create truly innovative and fresh concepts.



OBLIQUE

Iako u svojem katalogu nudi i namještaj baziran na provjerenim modelima, **prostor** je strateški, pa i strastveno posvećena istraživački orijentiranom dizajnu, vjerujući da izvornost ima svoje mjesto na tržištu, ali predstavlja i poseban izazov u vremenima kada se čini da je gotovo nemoguće osmisliti odista inovativne, svježije koncepte.





For that reason, **prostor**'s social responsibility and specific position have to be observed as a contribution to the evolution of design and readiness to take the risk in order to reach new values for the benefit of users and the culture. Thus, **prostor** stands as a distinct project inside of which designers grow together with the company on the grounds of mutual trust and shared goals. This is why designers and their creations have been given the leading role in this catalogue...



3ANGLE

Zato društvenu odgovornost, pa i specifičnu poziciju **prostor** treba promatrati upravo kao doprinos evoluciji dizajna, kao spremnost da se uđe u rizik kako bi se dosegle nove vrijednosti na dobrobit korisnika, ali i kulture. **prostor** je tako projekt u kojem zajednički rastu i dizajneri i tvrtka na temelju uzajamnog povjerenja i zajedničkih ciljeva. Zato se u ovom katalogu glavna riječ prepušta samim dizajnerima i njihovim radovima...

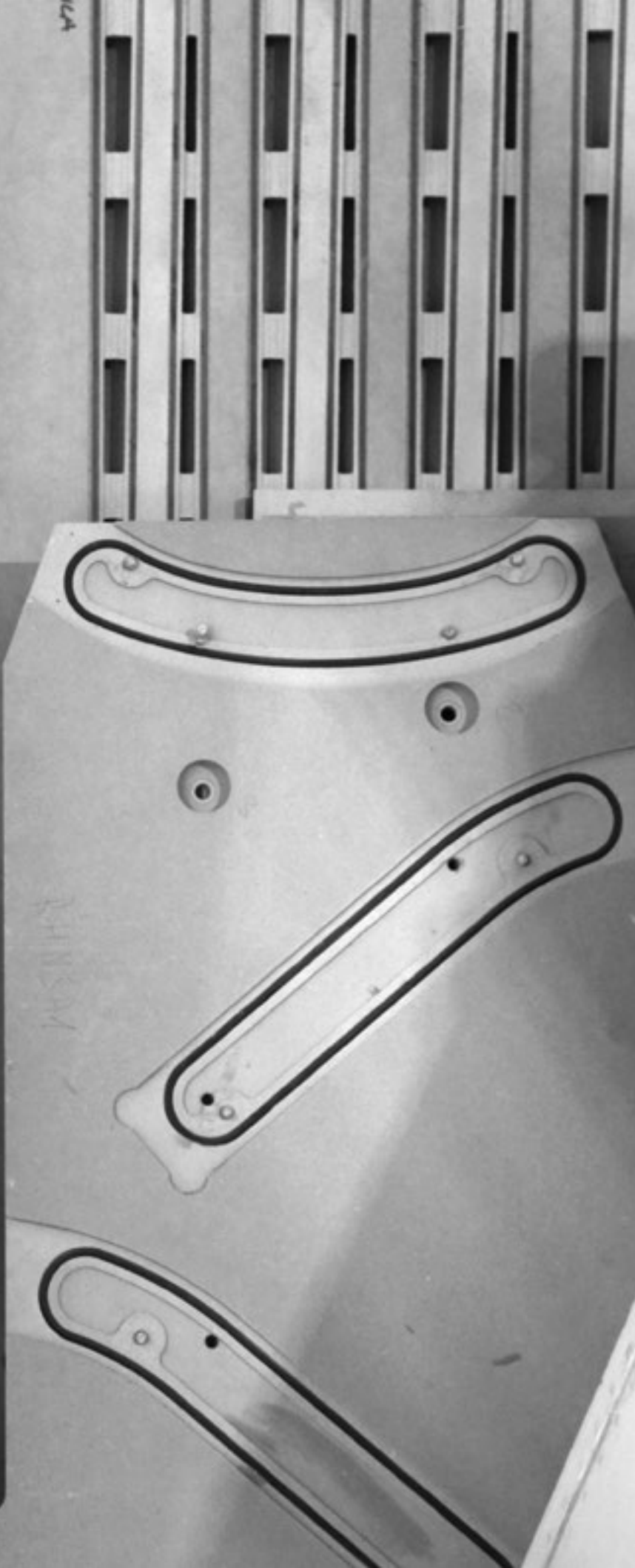
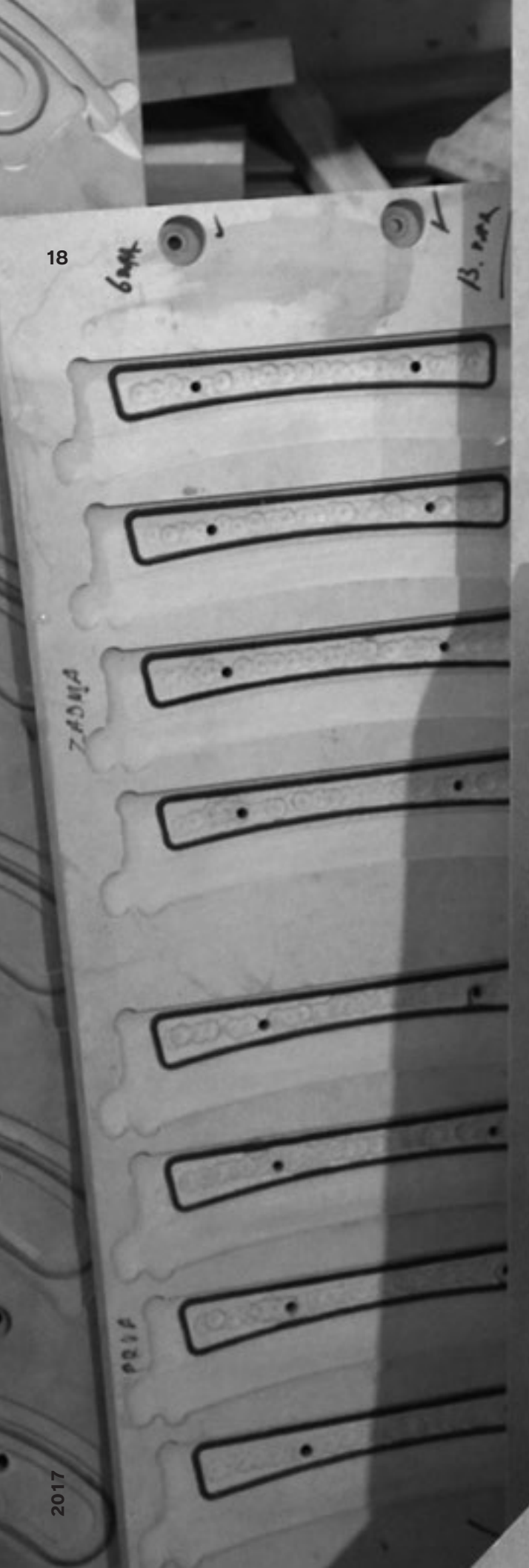

POLYGON 20



RHOMB 32



MONK 44



OBLIQUE 58



DOBRA 72



STRAIN 80



POLYGON



Ever since we first began to engage with design, we were fascinated with the standard modernist typology of chairs with modest dimensions that meet all functional parameters, without burdening the space with their bulkiness. We have explored a series of alternatives that are in line with these values, but also offer a new formal approach. *Polygon* retains all traditional elements of a modernist chair, but deconstructs them, creating new relations between them. The form of the bent steel bars of the structure, the seat and the backrest are coordinated via a triangular geometry. The composition of the triangle is accentuated when viewed from the side, but once the observer begins to move, these forms transform into hexagons and more complex polygons. We have continued to develop *Polygon* in close cooperation with **prostor**, and have launched a new version of the chair that retains all features of the original design, but in an improved form. The resulting product has a somewhat defamiliarizing effect, seeming both familiar and distinctly contemporary.

Od samog početka bavljenja dizajnom fascinirala nas je standardna modernistička tipologija sjedalice skromnih dimenzija koja zadovoljava sve funkcionalne parametre, a da pritom glomaznošću ne opterećuje prostore. Istraživali smo niz varijanti koje odgovaraju tim vrijednostima, ali nude i novi formalni pristup. U *Polygonu* su zadržani svi tradicionalni elementi modernističke stolice, no oni su dekonstruirani i dovedeni u nove odnose. Forma svinutih čeličnih šipki konstrukcije, sjedala i naslona koordinirana je trokutastom geometrijom. Kompozicija trokuta naglašena je u bočnom pogledu, no pri kretanju promatrača te forme se transformiraju u heksagone i kompleksnije poligone. U bliskoj suradnji s **prostor** nastavili smo razvijati *Polygon*, pa je danas na tržištu nova varijanta u kojoj su zadržane sve značajke dizajna koje su usavršene. Rezultat je ponešto začudni proizvod koji se doima poznatim, ali istovremeno i izrazito suvremenim.





ARMCHAIR / FABRIC
CANVAS, STRUCTURE
METAL COATED,
ARMRESTS ASHWOOD
FOTELJA / TKANINA
CANVAS, KONSTRUKCIJA
METAL PLASTICIFIRANI,
RUKONASLONI JASEN



***Polygon* retains all traditional elements of a modernist chair, but deconstructs them, creating new relations between them. The resulting product has a somewhat defamiliarizing effect, seeming both familiar and distinctly contemporary.**

U Polygonu su zadržani svi tradicionalni elementi modernističke stolice, no oni su dekonstruirani i dovedeni u nove odnose. Rezultat je ponešto začudni proizvod koji se doima poznatim, ali istovremeno i izrazito suvremenim.

NUMEN/FOR USE



ARMCHAIR / FABRIC
CANVAS, STRUCTURE
BLACK CHROME,
ARMRESTS WALNUT
FOTELJA / TKANINA
CANVAS, KONSTRUKCIJA
METAL CRNI KROM,
RUKONASLONI ORAH



ARMCHAIR / FABRIC
CANVAS, STRUCTURE
COPPER, ARMRESTS
ASHWOOD FOTELJA /
TKANINA CANVAS,
KONSTRUKCIJA METAL
BAKAR, RUKONASLONI
JASEN



Microsoft Executive Lounge, Vienna, Austria / Photo: Paul Ott



Restaurant Tatal Madrid, Spain / Project: Ilmiodesign, Andrea Spada & Michele Corbani / Photo: Uxio Davila

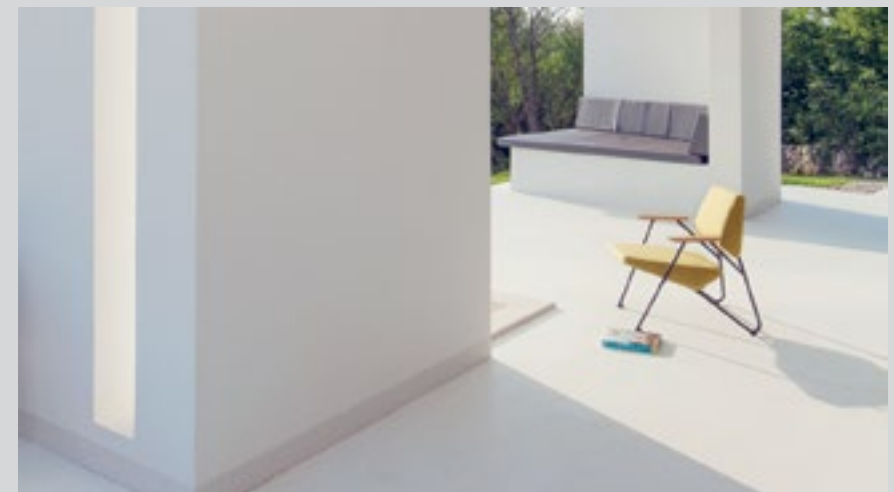

Villa The One, Kozljak, Istria, Croatia / Project: Denis & Lana Galić / Photo: Level52



ARMCHAIR / FABRIC
HALLINGDAL, STRUCTURE
METAL COATED, ARMRESTS
WALLNUT FOTELJA / TKANINA
HALLINGDAL, KONSTRUKCIJA
METAL PLASTIFICIRANI,
RUKONASLON ORAH

SMALL TABLE / LEGS
METAL COATED BLACK,
TABLE TOP FENIX NTM
STOLIĆ / NOGE METALNE
PLASTIFICIRANE CRNO,
PLOČA FENIX NTM





POLYGON

ARMCHAIR / FOTELJA

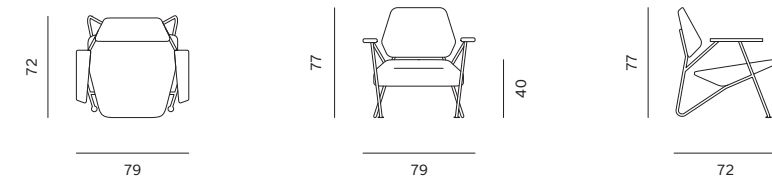

SMALL TABLE / STOLIĆ

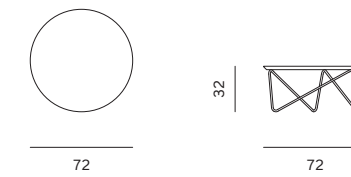

INTERIOR INNOVATION AWARD 2014 WINNER
GERMAN DESIGN AWARD 2015 WINNER

RHOMB



As a company, **prostor** is oriented to the production in solid wood, which has resulted in the creation of the *Rhomb* chair, my first project realized in that noble material. Our intention was to design a chair with a distinguishing identity combined with accentuated comfortableness. For that reason, our design includes a number of small but decisive shifts in geometry and ergonomics that have been meticulously researched in the course of the project development. The *Rhomb* is somewhat wider than a common chair while its backrest organically continues into prolonged armrests. This allows for various, more relaxed seating positions and feasting becomes a hedonic act. The chair's organic shape is in opposition with the contemporary rhomboid geometry found in the cross section of the backrest and legs. Tactile and visual qualities of solid wood are accentuated owing to the combination of the state-of-the-art technology and sophisticated manual processing.

Usmjerenost **prostor** prema proizvodnji u punom drvu dovela je do stolice *Rhomb*, moje prve realizacije u tome plemenitom materijalu. Namjera nam je bila dizajnirati stolicu prepoznatljivog identiteta, ali i naglašene udobnosti. Iz tog razloga dizajn uključuje niz malih, ali presudnih pomaka u geometriji i ergonomiji koji su pomno istraženi tijekom razvoja projekta. Stolica je nešto šira od uobičajene, a naslon za leđa organski se nastavlja u produžene rukonaslone. Tako su omogućene različite, opuštenije pozicije sjedenja, a blagovanje se doživljava kao hedonistički čin. Organičnoj konturi stolice suprotstavljena je suvremena, romboidna geometrija presjeka naslona i nogu. Zahvaljujući kombiniranju najsuvremenije strojne tehnologije i sofisticirane ručne obrade, naglašene su taktilne i vizualne kvalitete punog drveta.



The *Rhomb* is somewhat wider than a common chair while its backrest organically continues into prolonged armrests. This allows for various, more relaxed seating positions and feasting becomes a hedonic act.

Stolica je nešto šira od uobičajene, a naslon za leđa organski se nastavlja u produžene rukonaslone. Tako su omogućene različite, opuštenije pozicije sjedenja, a blagovanje se doživljava kao hedonistički čin.

SIMON MORASI PIPERČIĆ

CHAIR / OAK NATURE
STOLICA / HRAST NATUR

CHAIR / OAK LIGHT
STOLICA / HRAST LIGHT



CHAIR / OAK BLACK
STOLICA / HRAST CRNI

CHAIR / DARK RED
STOLICA / TAMNO CRVENA

CHAIR / WALNUT
STOLICA / ORAH





CHAIR / OAK NATURE
 STOLICA / HRAST NATUR





40

RHOMB

2017



41

RHOMB

prostorja





RHOMB

CHAIR / STOLICA

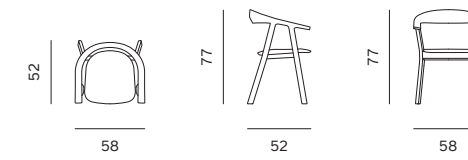
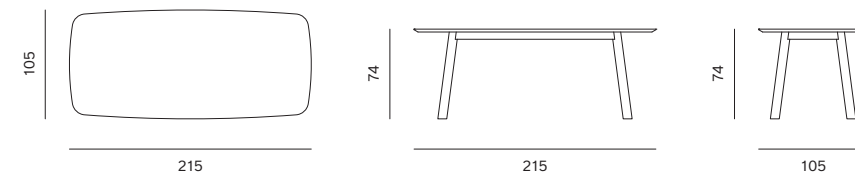

TABLE / STOL



GERMAN DESIGN
AWARD 2017 WINNER

MONK



The *Monk* collection brings together the regional modernist tradition and contemporary design. Originally, the chair and armchair were designed for the renovation of the architectural icon – the Palace Hotel in Dubrovnik. At the same time, they were homage to the very popular *Lupina* chair, a classic designed by Niko Kralj. This simple idea is reduced to finding harmony in joining two bended platforms: one for the backrest and the other expanding into the armrest. This results in an upholstered shell mounted on various types of legs – higher ones for the chair and lower ones for the armchair. The name for this collection is a figurative association that simultaneously follows the modernist ethics that inspired the team of designers: it seems as if an old monk dressed in modest cotton clothes decided to sit in an unpretentious wooden chair. The two *Monks*, a chair and an armchair, fuse the everyday life filled with *work* and *contemplation*. The collection is supplemented with low tables, a dining room table and a bar stool.

Kolekcija *Monk* povezuje regionalnu modernističku tradiciju i suvremeni dizajn. Stolac i naslonjač su izvorno projektirani za potrebe preuređenja arhitektonske ikone – dubrovačkog hotela *Palace*. Također, osmišljeni su kao *hommage* popularnom *Lupina* stolcu, klasiku slovenskog dizajnera Nike Kralja. Jednostavna zamisao svodi se na skladno povezivanje dviju savijenih ploha: jedne koja čini naslon i druge za sjedalo koja se širi u rukonaslon. Tako nastala tapecirana školjka postavljena je na različite tipove nogu, višima za stolac, nižima za naslonjač. Ime kolekcije je figurativna asocijacija, no ona je i na tragu modernističke etike koja nas je inspirirala: čini se kao da je neki stari monah u skromnoj platnenoj odjeći sjeo na nepretenciozan drveni stolac. Dva *Monka*, stolac i naslonjač, objedinjuju svakodnevnicu *rada* i *kontemplacije*. Uz njih kolekcija uključuje i niske stolice i stol za blagovanje.

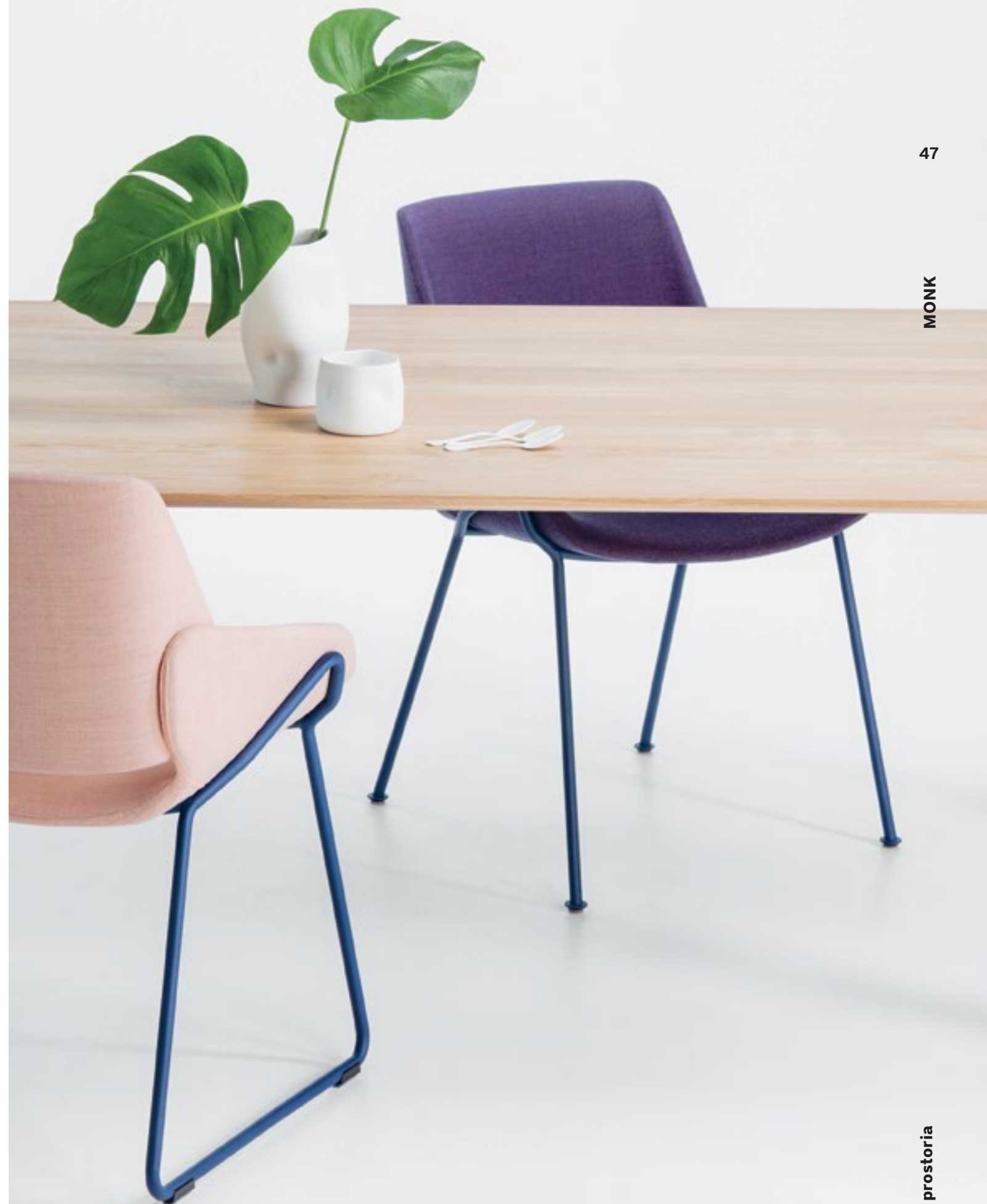

It seems as if an old monk dressed in modest cotton clothes decided to sit in an unpretentious wooden chair. The two *Monks*, a chair and an armchair, fuse the everyday life filled with *work* and *contemplation*.

Ime kolekcije je figurativna asocijacija, no ona je i na tragu modernističke etike koja nas je inspirirala: čini se kao da je neki stari monah u skromnoj platnenoj odjeći sjeo na nepretenciozan drveni stolac. Dva *Monka*, stolac i naslonjač, objedinjuju svakodnevicu *rada* i *kontemplacije*.

GRUPA





CHAIR / FABRIC
CANVAS, METAL
LEGS 5003 *STOLICA*
/ TKANINA CANVAS,
NOGE METALNE 5003



ARMCHAIR / FABRIC
CANVAS, METAL
LEGS 5003 *FOTELJA*
/ TKANINA CANVAS,
NOGE METALNE 5003



CHAIR / FABRIC CANVAS,
METAL SLED BASE 5003
STOLICA / TKANINA
CANVAS, NOGE METALNE
SKIJE 5003



ARMCHAIR / FABRIC
CANVAS, METAL SLED
BASE 5003 *FOTELJA* /
TKANINA CANVAS, NOGE
METALNE SKIJE 5003



CHAIR / FABRIC
CANVAS, LEGS OAK
NATURE *STOLICA* /
TKANINA CANVAS,
NOGE HRAST NATUR



Wooden House, Krk, Croatia / Project: Idis Turato / Photo: Bosnić+Dorotić



Meizai, Australia
Photo: Bek Sheppard

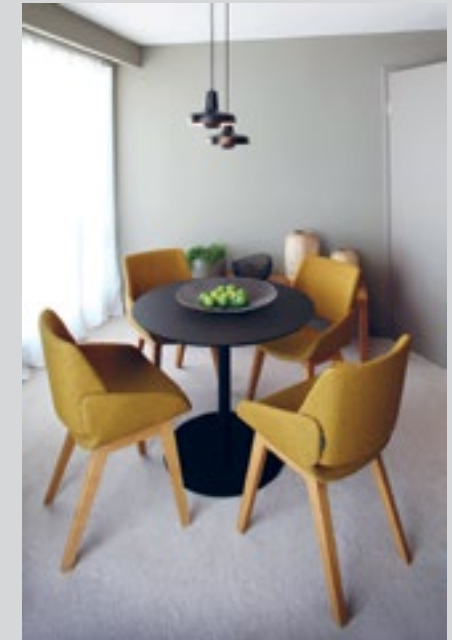
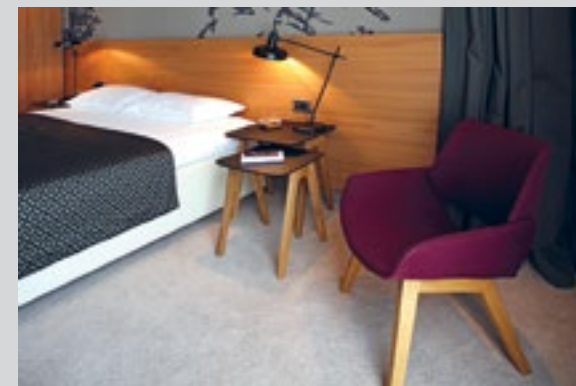
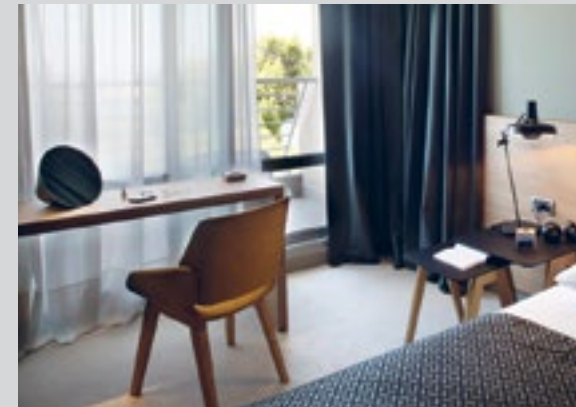

Hotel Palace, Dubrovnik, Croatia /
Project: 3LHD / Photo: Damir Fabijanić

CHAIR / FABRIC
CANVAS, LEGS OAK
LIGHT STOLICA /
TKANINA CANVAS,
NOGE HRAST LIGHT



TABLE / OAK NATURE
STOL / HRAST NATUR
100 x 100 CM



TABLE / OAK NATURE
STOL / HRAST NATUR
240 x 100 CM



TABLE / OAK NATURE
STOL / HRAST NATUR
180 x 100 CM



CHAIR / FABRIC
CANVAS, LEGS METAL
SLED BASE 9002
STOLICA / TKANINA
CANVAS, NOGE
METALNE SKIJE
9002



CHAIR / FABRIC
CANVAS, LEGS
METAL 7022
STOLICA / TKANINA
CANVAS, NOGE
METALNE 7022





ARMCHAIR /
FABRIC CANVAS,
LEGS OAK LIGHT
FOTELJA / TKANINA
CANVAS, NOGE
HRAST LIGHT



MONK

58

MONK

CHAIR / STOLICA

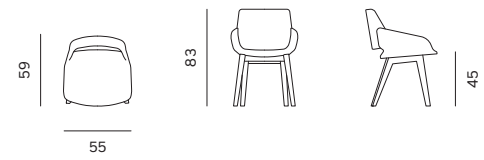

ARMCHAIR / FOTELJA

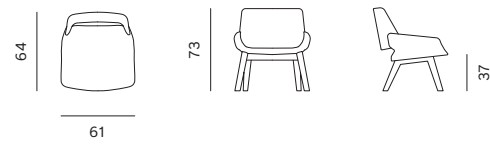

CHAIR SLED BASE / STOLICA SKIJE

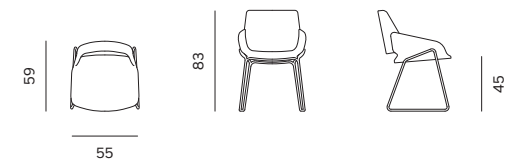

ARMCHAIR SLED BASE / FOTELJA SKIJE

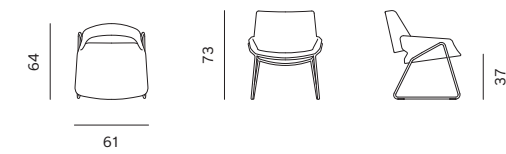

CHAIR METAL LEGS / STOLICA METALNE NOGE

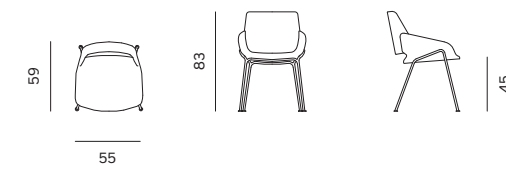

ARMCHAIR METAL LEGS / FOTELJA METALNE NOGE

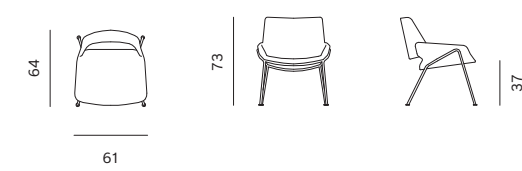

SMALL TABLE MIDI / STOLIĆ MIDI

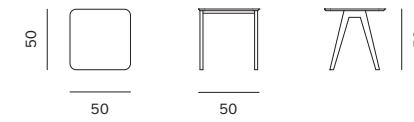

SMALL TABLE MINI / STOLIĆ MINI

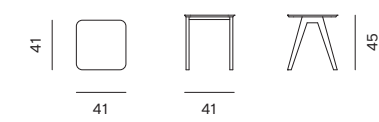
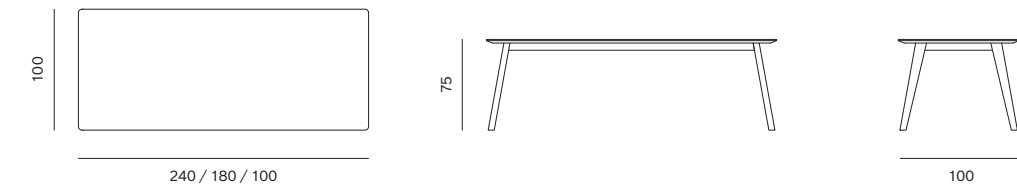
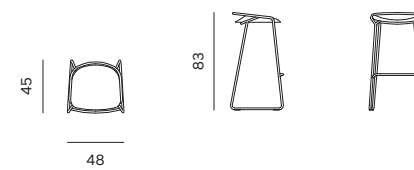

TABLE / STOL



BAR STOOL / BARSKI STOLAC



59

MONK

2017

prostorija

OBLIQUE



When designing the *Oblique* family of products, we wanted to ensure a quality sitting experience for the user in a real soft armchair, but within minimal dimensions. It is these requirements that have created the recognizable profile of this set of chairs. The profile underlines two triangular prisms. They ensure the greatest thickness of the foam on the major points of support for the body when sitting: the back side of the seat and the lumbar zone of the backrest. The narrowed plane where the volume from the seat blends into the backrest improves the ergonomics, but also allows for the elasticity of the backrest. The top of the legs has a rectangular cross-section, but becomes increasingly thin towards the bottom, turning ultimately into a triangular base. This way, we have reduced the robustness of the wooden profiles of the structure and have given the design a geometric expressive and contemporary character. We have perfected the products through time, offering, in addition to the wooden leg structure, an alternative metal version that also includes an armrest. The *Oblique* family also comprises a larger table and smaller coffee tables.

Prilikom dizajniranja obitelji proizvoda *Oblique* željeli smo korisniku osigurati kvalitetu sjedenja u pravoj, mekanoj fotelji, no u minimalnim gabaritima. Iz tih zahtjeva proizlazi i prepoznatljiv profil sjedala obitelji. U profilu se ističu dvije trokutaste prizme. One osiguravaju najveće debljine pjene na glavnim točkama oslonaca tijela pri sjedenju: stražnjoj strani sjedala i lumbalnoj zoni naslona. Sužena ploha pretapanja volumena iz sjedala u naslon poboljšava ergonomiju, ali i omogućava elastičnost naslona. Vrh nogu kvadratnog presjeka se stanjuje i triangulacijom prelazi u trokut baze. Na taj način smanjili smo robusnost drvenih profila konstrukcije i dizajnu pridali geometrijski ekspresivan, suvremen karakter. Proizvodi su usavršavani tijekom vremena, a uz drvenu konstrukciju nogu nudi se i varijanta u metalu koja ima i rukonaslon. Obitelj *Oblique* uključuje i veći stol i stolić.





CHAIR / FABRIC
DIVINA 3, LEGS
OAK LIGHT
STOLICA / TKANINA
DIVINA 3, NOGE
HRAST LIGHT



TABLE / LEGS OAK
NATURE, TABLE
TOP FENIX NTM
STOL / NOGE HRAST
NATUR, PLOČA
FENIX NTM



CHAIR / FABRIC
DIVINA MD, LEGS
OAK LIGHT
STOLICA / TKANINA
DIVINA MD, NOGE
HRAST LIGHT

The profile underlines two triangular prisms. They ensure the greatest thickness of the foam on the major points of support for the body when sitting.

U profilu se ističu dvije trokutaste prizme. One osiguravaju najveće debljine pjene na glavnim točkama oslonaca tijela pri sjedenju.

NUMEN/FOR USE



CHAIR / FABRIC
DIVINA MD, LEGS
OAK LIGHT
STOLICA / TKANINA
DIVINA MD, NOGE
HRAST LIGHT

prostorja





Wooden House, Krk, Croatia / Project: Idis Turato
Photo: Bosnić+Dorotić



JGL Pharma Valley Rijeka, Croatia
Project: Igor Rožić & Davor Katušić with
associates / Photo: Sandro Rubinić



Play: King Lear, Athens, Greece / Scenography: Numen/ForUse / Photo: Aljoša Rebolj & Numen/ForUse



ARMCHAIR / FABRIC
 HALLINGDAL 65,
 LEGS OAK BLACK
 FOTELJA / TKANINA
 HALLINGDAL 65,
 NOGE HRAST CRNI



OBLIQUE

72

OBLIQUE

CHAIR / STOLICA

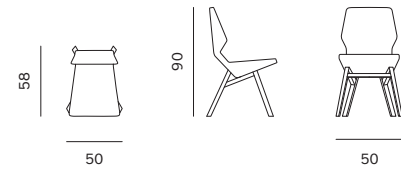

CHAIR METAL / STOLICA METALNA

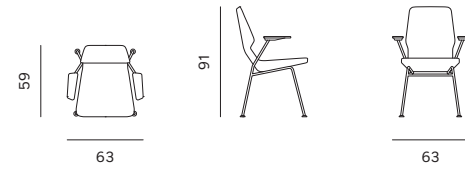

LOUNGE CHAIR / FOTELJA

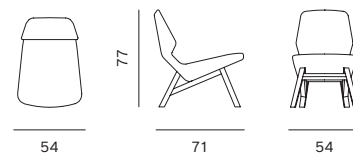

ARMCHAIR METAL / FOTELJA METALNA

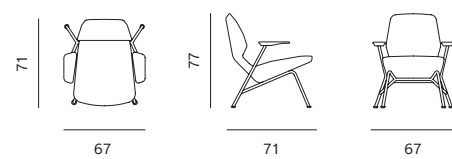

ARMCHAIR / FOTELJA S RUKONASLONIMA

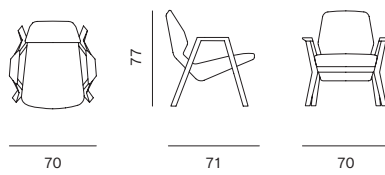

SMALL TABLES / STOLIĆI

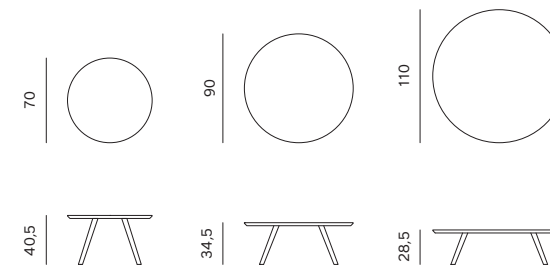

DINING TABLE / STOL

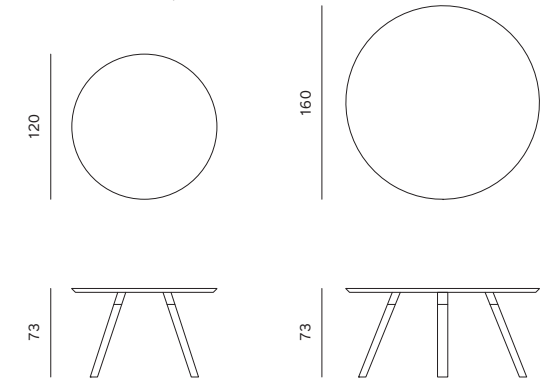

DINING TABLE / STOL

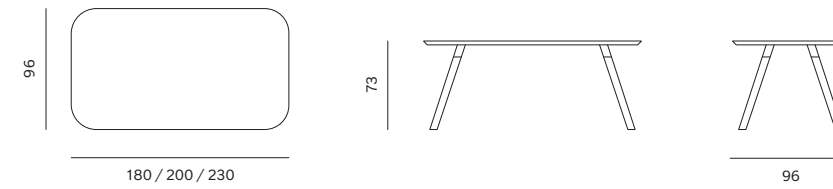

73

OBLIQUE

prostorija

2017



RED DOT DESIGN
AWARD 2015 WINNER

DOBRA



We have reinterpreted the traditional typology of a wooden chair with armrests using a characteristic 'break' in the geometry of front legs. Rounded geometry of turned armrests and the backrest is mirrored in the lenticular cushions. Primarily functional intersection between the legs and transversal bars on the seat maintains geometrical exactness. Intersections between the backrest and armrests, perceptible by touch, were created according to the principles of organic transformation of volume. Those contrasts between 'soft' and 'hard' elements and intersections shape the *Dobra's* characteristic formal language.

Tradicionalnu tipologiju drvenog stolca s rukonaslonima reinterpretirali smo karakterističnim "lomom" geometrije prednjih nogu. Zaobljena geometrija tokarenih rukonaslona i naslona zrcali se u jastucima oblika leće. Primarno funkcionalni spoj nogu i poprečnih prečki sjedala ostavili smo geometrijski egzaktnim. Spojeve naslona i rukonaslona, koji korisnik neposredno taktilno doživljava, oblikovali smo prema načelima organskog pretapanja volumena. Upravo ti kontrasti "mekih" i "tvrdih" elemenata i spojeva čine karakteristični formalni jezik *Dobre*.





CHAIR / FABRIC
 STEELCUT TRIO 2,
 OAK BLACK
 STOLICA / TKANINA
 STEELCUT TRIO 2,
 HRAST CRNI



CHAIR / FABRIC
 REMIX, OAK LIGHT
 STOLICA / TKANINA
 REMIX, HRAST
 LIGHT



**We have reinterpreted
 the traditional typology
 of a wooden chair
 with armrests using a
 characteristic 'break'
 in the geometry of
 front legs.**

Tradicionalnu tipologiju
 drvenog stolca
 s rukonaslonima
 reinterpetirali smo
 karakterističnim
 "lomom" geometrije
 prednjih nogu.

NUMEN/FOR USE



DOBRA

CHAIR / STOLICA

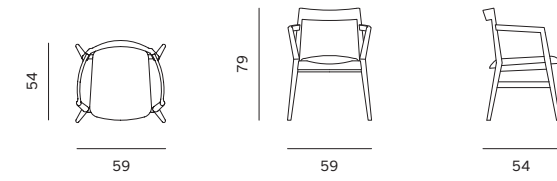

STRAIN



The *Strain* product family comprises an armchair, a bar stool and tables and small tables of various heights. This diversified product family shares one common feature: the design of the product base and legs, which is always a challenge. The solution for very distinguishable leg junctions is found in intertwining and intertwisting of steel tubes whose modular relations can change depending on a particular use. The result is a recognizable family of products with variations of a common basic idea where the concept of junctions is not only an appealing formal interplay but also an element that complements the hardness of the construction. Visually light and uncustomary slender, the *Strain* armchair offers extraordinary comfort due to the elasticity of leather and net fabric tightly stretched over the seat shell. A lumbar cushion provides additional comfortableness. A saddle served as the inspiration for the ergonomic design of the solid wood seat of the barstool. This entirely functional family is rounded off with multidimensional coffee tables with various finishes.

Obitelj proizvoda *Strain* uključuje fotelju, barski stolac i stolove i stoliće u dvije visine. Tu šaroliku obitelj objedinjuje oblikovanje nogu i baze produkta, koji su uvijek izazov. Specifični spojevi nogu riješeni su međusobnim ispreplitanjem i obavijanjem čeličnih cijevi čiji se odnosi mijenjaju ovisno o pojedinačnim namjenama. Tako je nastala obitelj prepoznatljiva po varijacijama zajedničke osnovne zamisli, a koncept spojeva nije samo dopadljiva formalna igra, nego i doprinosi krutosti konstrukcije. Vizualno lagan i neuobičajeno tanak naslonjač *Strain* posebno je udoban zahvaljujući elastičnosti kože ili mrežastog materijala koji su napeti preko ljuske sjedala. Udobnosti doprinosi i lumbalni jastuk. Ergonomski oblikovano sjedalo barskog stolca od masivnog drveta inspirirano je sedlom. Stolići dviju dimenzija i dostupni u tri boje zaključuju potpuno funkcionalnu obitelj.

SMALL TABLE / TABLE
STRUCTURE METAL
COATED BLACK CHROME,
TABLE TOP FENIX NTM
STOLIĆ / KONSTRUKCIJA
METALNA PLASTIFICIRANA
CRNI KROM, PLOČA
FENIX NTM



ARMCHAIR /
FABRIC CRAGGAN,
STRUCTURE METAL
COATED BLACK
CHROME
FOTELJA /
TKANINA CRAGGAN,
KONSTRUKCIJA
METALNA
PLASTIFICIRANA
CRNI KROM





ARMCHAIR / FABRIC
 HALLINGDAL 65, STRUCTURE
 METAL COATED BLACK
 FOTELJA / TKANINA
 HALLINGDAL 65,
 KONSTRUKCIJA METALNA
 PLASTIFICIRANA CRNA

This diversified product family shares one common feature: the design of the product base and legs, which is always a challenge. The solution for very distinguishable leg junctions is found in intertwining and intertwisting of steel tubes whose modular relations can change depending on a particular use.

Šaroliku obitelj objedinjuje oblikovanje nogu i baze produkta, koji su uvijek izazov. Specifični spojevi nogu riješeni su međusobnim ispreplitanjem i obavijanjem čeličnih cijevi čiji se odnosi mijenjaju ovisno o pojedinačnim namjenama.

SIMON MORASI PIPERČIĆ



ARMCHAIR / MESH RUNNER,
FABRIC STEELCUT TRIO 2,
STRUCTURE METAL COATED
FOTELJA / MREŽA RUNNER,
TKANINA STEELCUT TRIO 2,
KONSTRUKCIJA METALNA
PLASTIFICIRANA



ARMCHAIR / MESH RUNNER,
FABRIC STEELCUT TRIO 2,
STRUCTURE METAL COATED
FOTELJA / MREŽA RUNNER,
TKANINA STEELCUT TRIO 2,
KONSTRUKCIJA METALNA
PLASTIFICIRANA



STOOL / SEAT OAK NATURE,
LEGS METAL COATED BLACK
STOLAC / SJEDALO HRAST
NATUR, NOGE METAL
PLASTIFICIRAN CRNO

ARMCHAIR / MESH RUNNER,
FABRIC STEELCUT TRIO 2,
STRUCTURE METAL COATED
FOTELJA / MREŽA RUNNER,
TKANINA STEELCUT TRIO 2,
KONSTRUKCIJA METALNA
PLASTIFICIRANA



STRAIN

LOUNGE CHAIR / FOTELJA

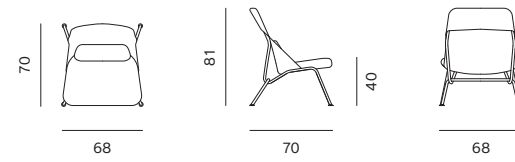

SMALL TABLE / STOLIĆ

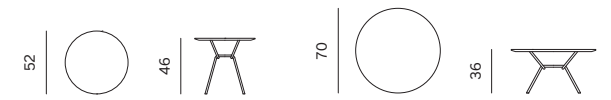

BAR STOOL HIGH
/ BARSKI STOLAC
VISOKI

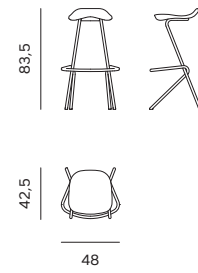

BAR STOOL LOW
/ BARSKI STOLAC
NISKI

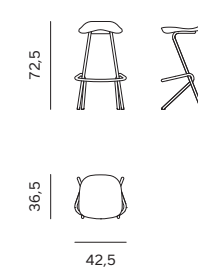

STOOL
/ STOLAC

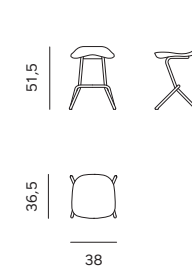

TABLE / STOL

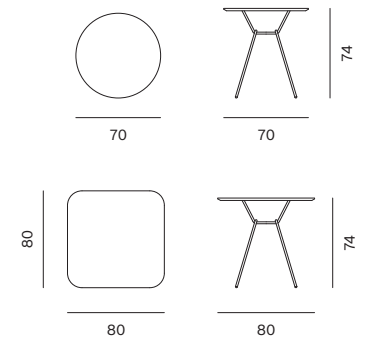
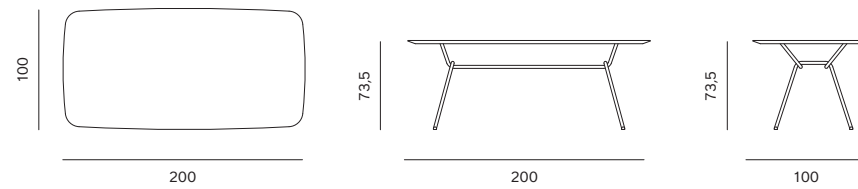

TABLE / STOL



INTERIOR INNOVATION AWARD 2015 WINNER
RED DOT DESIGN AWARD 2015 WINNER
GOLDEN KEY AWARD 2015 WINNER

3ANGLE 94



COMBINE 104



MATCH 114



CLOUD 126



ELEGANCE 136

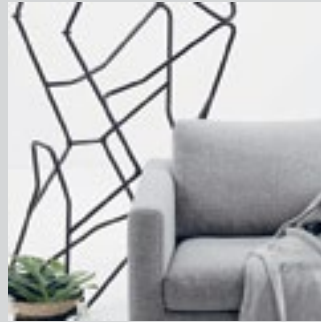

CLASSIC 144

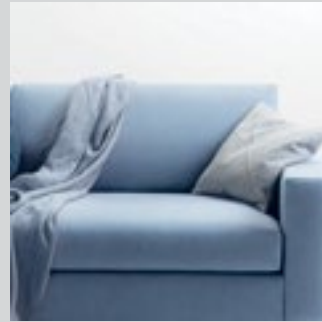

CONVERT 152



SEGMENT 162

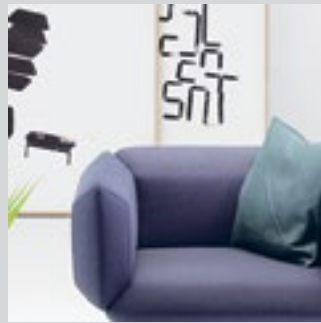

SEAM 174

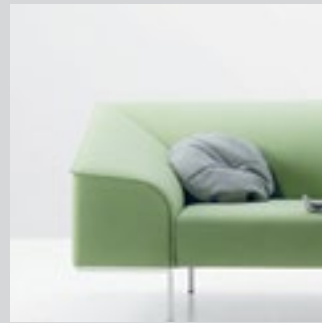

FRAME 182



COMBO 184

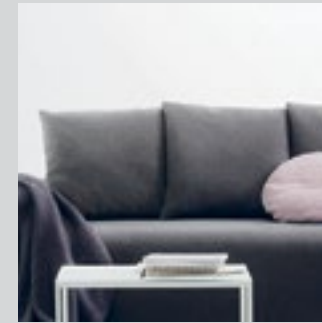

UP-LIFT 192



REVOLVE 200



PIL-LOW 208



SIMETRIA 214

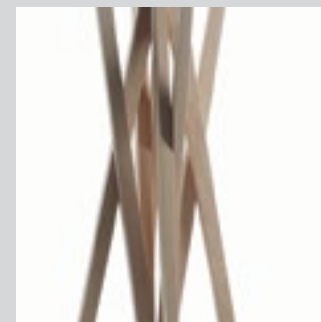

3ANGLE



The *3angle* armchair and two-seater sofa is a result of mindful and persistent product development that **prostor** grants to its designers. Following a competition in 2011, the project has undergone a number of transformations tested on prototypes while simultaneously preserving the original design idea. Fragmented, crystal-like forms systematically describing a compact volume, almost like an algorithm, characterize the design. This solution is not only formal - the characteristic *3angle* armrests follow the ergonomic line of relaxed arms. A soft shell of the backrest and armrest is covered with a continuous cover whose edges are marked only with a very subtle line of stitches. A light metal sub-construction reproduces the characteristic triangular motif contributing to the compactness of the composition. The *3angle* is a self-confident yet very disciplined formal step forward whose strong identity does not interfere with fitting in various ambiances.

Naslonjač i dvosjed *3angle* rezultat su brižljivog i dugotrajnog razvoja proizvoda koji **prostor** osigurava dizajnerima. Nakon natječaja iz 2011. godine projekt je prošao niz preobrazbi testiranih na prototipovima, pri čemu je izvorna oblikovna ideja čitavo vrijeme zadržana. Dizajn karakteriziraju razlomljene kristalične plohe koje sustavno, poput matematičkog algoritma, opisuju kompaktni volumen. Rješenje nije samo formalno jer karakteristični rukonasloni prate ergonomski opušten položaj ruku. Mekana školjka naslona i rukonaslona prekrivena je kontinuiranom presvlakom na kojoj su bridovi samo naznačeni tankim šavovima. Tanki crna metalna potkonstrukcija ponavlja karakterističan motiv trokuta što doprinosi kompaktnosti kompozicije. *3angle* je samouvjeren, no i vrlo discipliniran formalni iskorak čiji snažni identitet ne priječi uklapanje u raznolike ambijente.





ARMCHAIR / FABRIC
DIVINA MD, LEGS
METAL COATED
BLACK 9005
FOTELJA / TKANINA
DIVINA MD,
NOGE METALNE
PLASTIFICIRANE
CRNO 9005



Fragmented, crystal-like forms systematically describing a compact volume, almost like an algorithm, characterize the design. *3angle* is a self-confident yet very disciplined formal step forward whose strong identity does not interfere with fitting in various ambiances.

Dizajn karakteriziraju razlomljene kristalične plohe koje sustavno, poput matematičkog algoritma, opisuju kompaktni volumen. *3angle* je samouvjeren, no i vrlo discipliniran formalni iskorak čiji snažni identitet ne priječi uklapanje u raznolike ambijente.

GRUPA



2SEATER / FABRIC
DIVINA MD, LEGS
METAL COATED
BLACK 9005
2S.JED / TKANINA
DIVINA MD,
NOGE METALNE
PLASTIFICIRANE
CRNO 9005

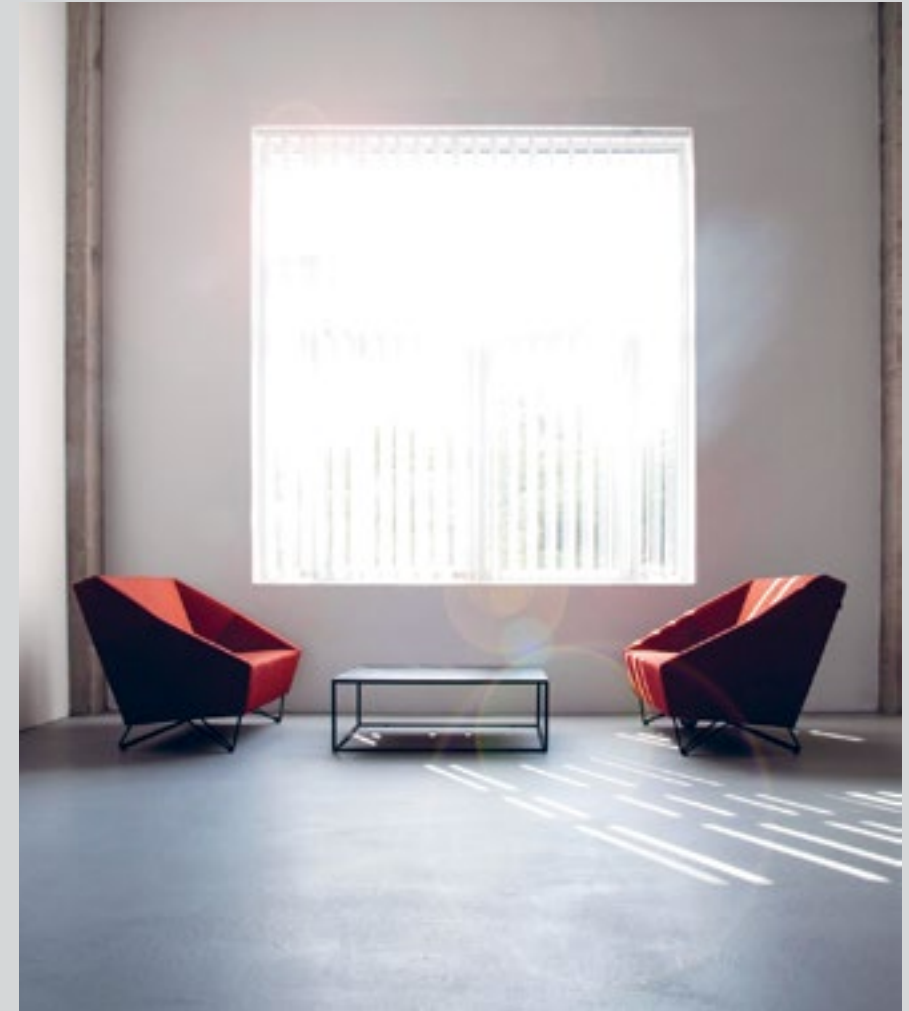

Seven Bridges Genomics offices, New Belgrade, Serbia / Project: Antipod studio / Photo: Marinka Tanasković



Marina Poreč, Croatia
Project: Krebel Kostrenčić
Architects / Photo:
Mijenko Bernfest Berni

POUF / FABRIC
DIVINA MD, DIVINA 3,
LEGS METAL COATED
BLACK 9005
TABURE / TKANINA
DIVINA MD, DIVINA
3, NOGE METALNE
PLASTIFICIRANE
CRNO 9005





3ANGLE

ARMCHAIR / FOTELJA

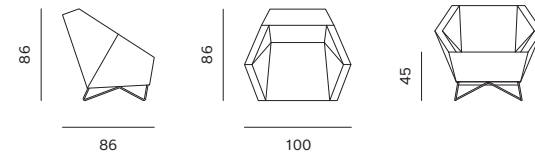

2SEATER / 2SJED

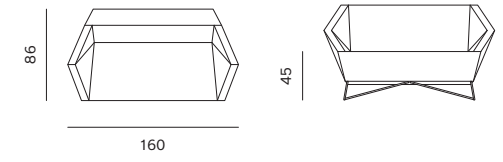

POUF / TABURE

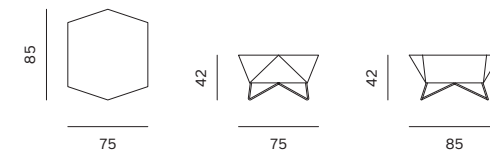

4ANGLE SMALL TABLE / 4ANGLE STOLIĆ

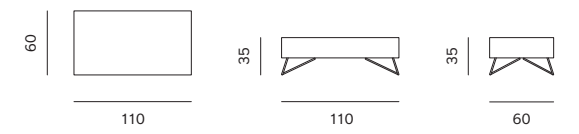

COMBINE



A standard sofa with feather cushions served as the starting point in designing the *Combine*. This standard form provides the most comfortable sitting but it is usually very voluminous. Our solution introduces sloped lateral and rear parts of the backrest, which results in both visual and literal reduction of the backrest's volume and height. Horizontal surfaces following the line of the extended seating and laying module are designed to serve both for sitting and putting things away. Depending on the selection of wooden or metal legs and extra cushions, the *Combine's* style and context of use change, offering an opportunity to every user to define the character of the sofa individually.

Ishodište *Combinea* je standardna sofa s dodanim pernaticim jastucima. Taj standardni oblik osigurava najvišu kvalitetu sjedenja, ali je obično i naglašeno voluminozan. Naše rješenje uvodi skošenje bočnoga i stražnjega donjeg dijela naslona, čime se postiže i vizualno i doslovno smanjenje volumena i visine naslona. Horizontalne plohe uz rubove produženog modula za sjedenje i ležanje dizajnirane su tako da mogu služiti i za sjedenje i za odlaganje priručnih stvari. Ovisno o izboru drvenih ili metalnih nogu te dodatnih jastuka, stil i kontekst uporabe *Combinea* se mijenja, pružajući korisniku vlastitu definiciju karaktera sofe.



2SEATER / FABRIC
 OPERA MIRROR, LEGS
 WALNUT, COPULINGS
 COATED BLACK 9005
 2S JED / TKANINA
 OPERA MIRROR, NOGICE
 ORAH, POVEZNICE
 PLASTIFICIRANE
 CRNE

Our solution introduces sloped lateral and rear parts of the backrest, which results in both visual and literal reduction of the backrest's volume and height.

Naše rješenje uvodi skošenje bočnoga i stražnjega donjeg dijela naslona, čime se postiže i vizualno i doslovno smanjenje volumena i visine naslona.

NUMEN/FOR USE

MONK ARMCHAIR /
 FABRIC CANVAS,
 LEGS OAK NATURE
FOTELJA / TKANINA
 CANVAS, NOGE
 HRAST NATUR



CHAISE LOUNGE / FABRIC
 SYNERGY, LEGS WALNUT,
 COUPLING COATED BLACK 9005
 PRODUŽENI DIO / TKANINA
 SYNERGY, NOGE ORAH,
 POVEZNICE PLASTIFICIRANE
 CRNE 9005



Meizai, Australia / Photo: Bek Sheppard



Microsoft DOOEL Skopje
 Author: KL studio
 Project Management:
 BATES doo Belgrade
 Photo: Andrijana Tilic



Private apartment, Paris, France / Project and photo: Atelier tropique



COMBINE

3SEATER / 3SJED, 2,5SEATER / 2,5SJED, 2SEATER / 2SJED,

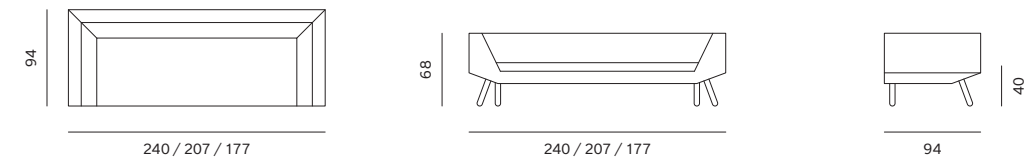

END UNIT (L/R) / ZAVRŠETAK (L/D)

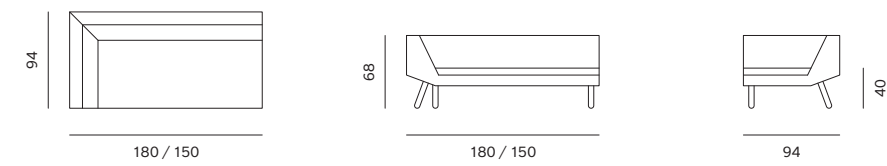

CHAISE LOUNGE (L/R) / PRODUŽENI DIO (L/D)

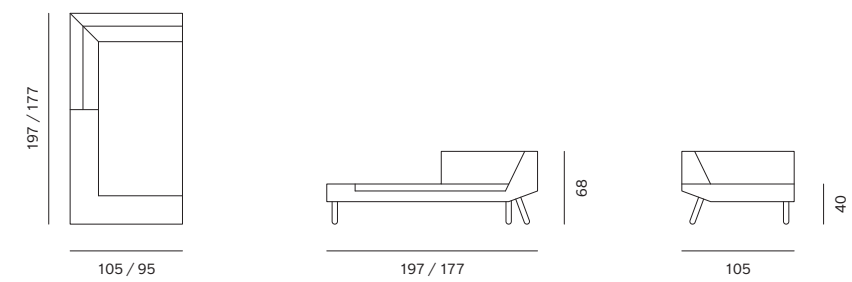

MATCH



The *Match* modular sofa reflects the standards of good design; however, its appearance and ways of using suggest a subtle break from the convention. The backrest is somewhat lower while the armrests are elevated which results in a specific composition and sitting experience. The user can choose between two different widths or depths of the module to obtain spatially and functionally optimal sofa. Its discretely designed form accentuates colours and textures of a variety of fabrics. The *Match* is an example of a well-designed sofa reduced to essential solutions. This approach made it one of the most successful products designed by **prostor**.

Modularna sofa *Match* odražava standarde dobrog dizajna, no njena pojavnost i načini korištenja donose suptilne pomake u odnosu na konvencije. Naslonjač je nešto niži, a rukonasloni povišeni, što utječe i na specifičnost kompozicije i na iskustvo sjedenja. Korisnik može birati između dviju širina i dviju dubina modula kako bi dobio prostorno i funkcionalno optimalnu sof, a diskretnim oblikovanjem forme naglasak je stavljen na boje i teksture tkanina. *Match* je primjer dobrog dizajna svedenog na esencijalna rješenja, a takav pristup učinio ga je jednim od najuspješnijih **prostor**ijinih proizvoda.



POLYGON
ARMCHAIR /
FOTELJA

MODULAR COMPOSITION
 / FABRIC MOLLY 2
 MODULARNA KOMPOZICIJA
 / TKANINA MOLLY 2



POUF /
 FABRIC
 MOLLY 2
 TABURE /
 TKANINA
 MOLLY 2

STRAIN ARMCHAIR /
 FABRIC HALLINGDAL 65,
 STRUCTURE METAL
 COATED BLACK
 FOTELJA / TKANINA
 FABRIC HALLINGDAL 65,
 KONSTRUKCIJA METALNA
 PLASTIFICIRANA
 CRNI LAK

Discretely designed form accentuates colours and textures of a variety of fabrics. The *Match* is an example of a well-designed sofa reduced to essential solutions.

Diskretnim oblikovanjem forme naglasak je stavljen na boje i teksture tkanina. *Match* je primjer dobrog dizajna svedenog na esencijalna rješenja.

SANJA KNEZOVIĆ

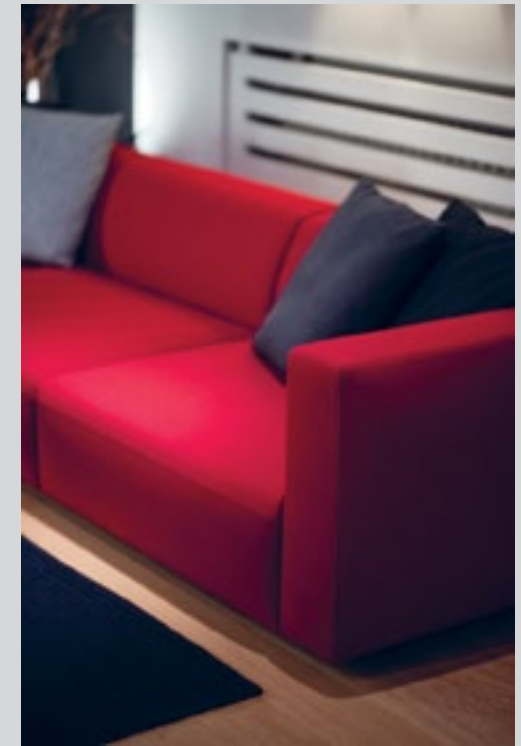

Prostoria Showroom, Zagreb / Photo: Vanja Šolin



LeviNine offices, Belgrade, Serbia
Project: OSA projekti, Ivana Kovačević / Photo: Relja Ivanić



Seven Bridges Genomics offices, New Belgrade, Serbia
Project: Antipod studio / Photo: Relja Ivanić





MATCH

1SEATER / 1SJED

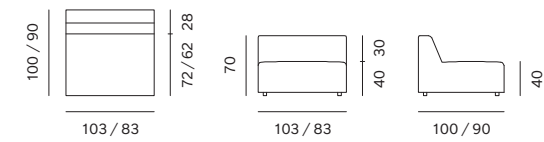

1SEATER + ARMREST (L/R) / 1SJED + RUKONASLON (L/D)

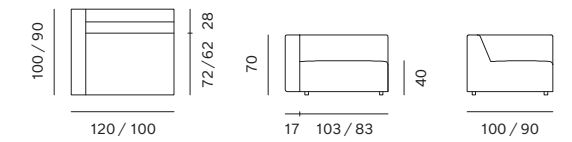

1SEATER EXTENDED (L/R) / 1SJED PRODUŽENI (L/D)

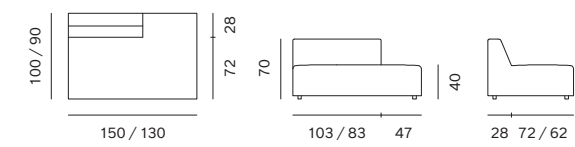

CORNER / KUT

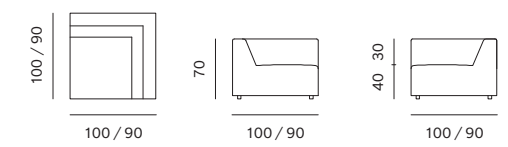

CORNER EXTENDED (L/R) / KUT PRODUŽENI (L/D)

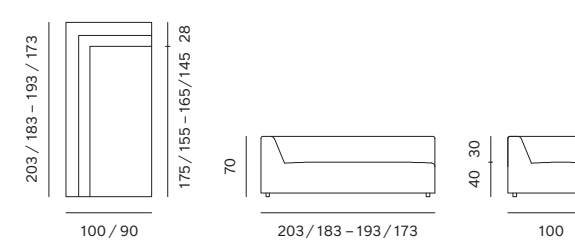

CHAISE LOUNGE (L/R) / PRODUŽENI DIO (L/D)

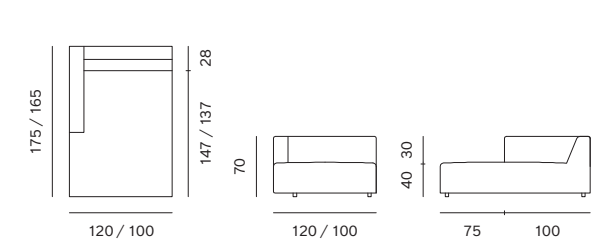

2SEATER + ARMREST (L/R) / 2SJED + RUKONASLON (L/D)

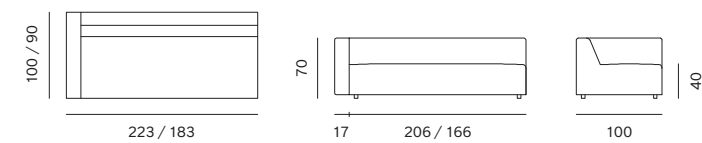

ISLAND / OTOK

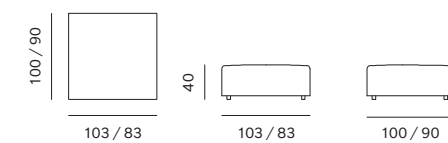

ARMCHAIR / FOTELJA

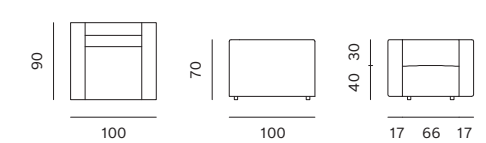

POUF / TABURE

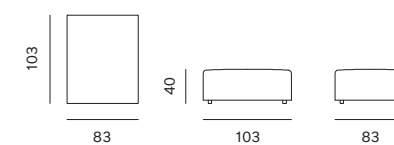

POUF / TABURE

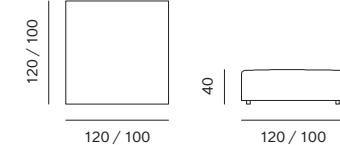

CLOUD



The *Cloud* sofa was created as an opposing reaction to the basic model and pattern used for the design of the *Match* sofa. This visually attractive sofa with simple lines invites you to sit down and relax. The support made of cold foam reinforces the volume while the surface feather-filled layer provides a unique softness and sense of taking a rest in the midst of clouds. Modularity and variety of armrests allow for a very wide scope of functions. However, the *Cloud* sofa is particularly suitable for large spaces. It is particularly impressive in aniline leather upholstery with accentuated details on the seams.

Sofa *Cloud* nastala je kao reakcija i suprotnost osnovnom modelu i obrascu po kojem je dizajnirana sofa *Match*. Vizualno privlačna i jednostavnih linija, sofa poziva na sjedenje. Potpora od hladne pjene učvršćuje volumen sofe, a površinski sloj punjen perjem osigurava jedinstvenu mekoću i osjećaj odmora među oblacima. Modularnost i varijacije rukonaslona osiguravaju široku primjenu, no *Cloud* posebno dobro pristaje velikim prostorima. Naročito upečatljivo djeluje tapacirana u anilinsku kožu, s naglašenim detaljima spojeva.

CHAISE LOUNGE /
FABRIC HALLINGDAL 65
PRODUŽENI DIO /
TKANINA HALLINGDAL 65



This visually attractive sofa with simple lines invites you to sit down and relax. Modularity and variety of armrests allow for a very wide scope of functions. However, the *Cloud* sofa is particularly suitable for large spaces.

Vizualno privlačna i jednostavnih linija, sofa poziva na sjedenje. Modularnost i varijacije rukonaslona osiguravaju široku primjenu, no *Cloud* posebno dobro pristaje velikim prostorima.

SANJA KNEZOVIĆ

MODULAR COMPOSITION /
FABRIC HALLINGDAL 65
MODULARNA KOMPOZICIJA
/ TKANINA HALLINGDAL 65



RHOMB
CHAIR /
OAK LIGHT
STOLICA
/ HRAST
LIGHT

MONK TABLE
/ OAK NATURE
STOL / HRAST
NATUR
100 x 100 CM

130

CLOUD

131

CLOUD

2017

prostorija

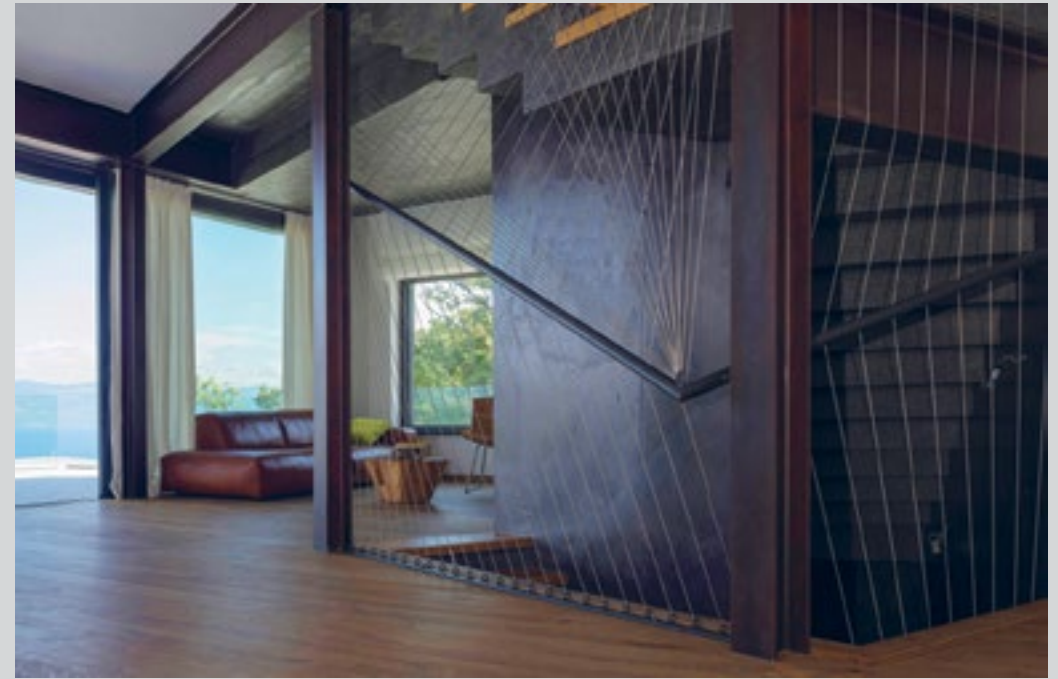

Private house Gumno, Krk, Croatia / Project: Idis Turato / Photo: Bosnić+Dorotić



Studio Scenography, Zagreb, Croatia / Photo: Domagoj Kunić

TKANINA / FABRIC
HALLINGDAL 65

136

CLOUD



CLOUD

137

CLOUD

1SEATER / 1SJED

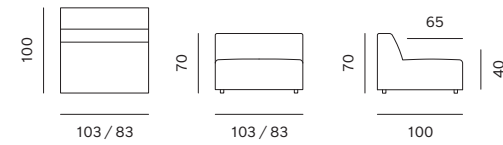

1SEATER + ARMREST (L/R) / 1SJED + RUKONASLON (L/D)

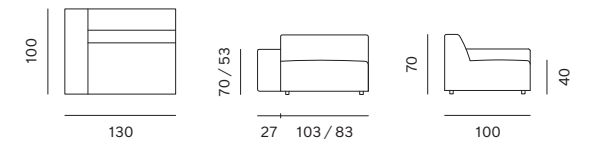

2SEATER + ARMREST (L/R) / 2SJED + RUKONASLON (L/D)

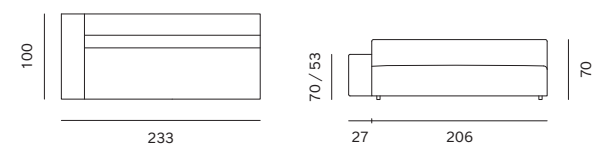

ISLAND / OTOK

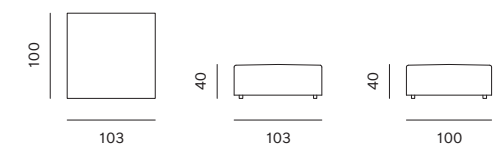

CHAISE LOUNGE (L/R) / PRODUŽENI DIO (L/D)

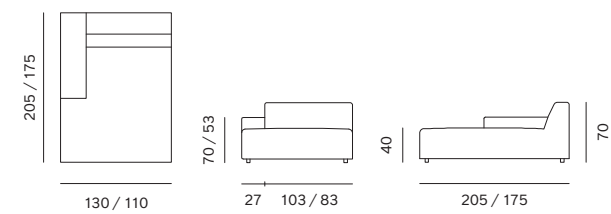

CORNER / KUT

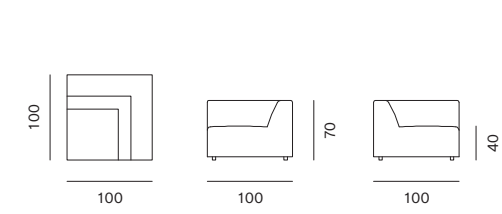

CORNER ASIMETRICAL (L/R) / KUT ASIMETRIČNI (L/D)

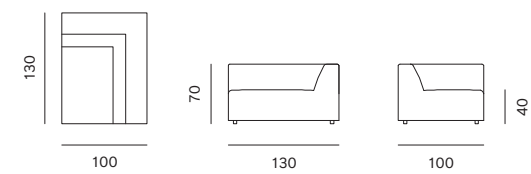

ARMCHAIR / FOTELJA

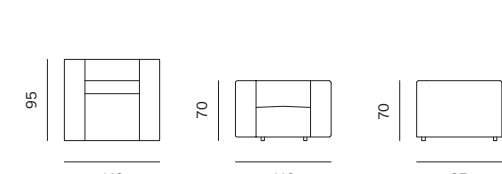

1SEATER EXTENDED (L/R) / 1SJED PRODUŽENI (L/D)

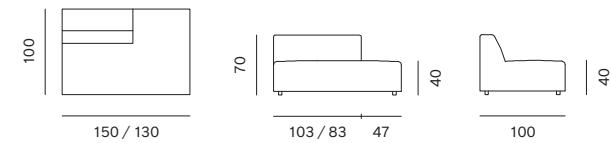

POUF / TABURE

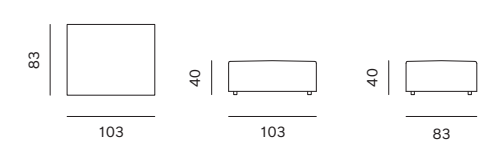

2017

prostorja

ELEGANCE

The *Elegance*, together with the *Classic*, represents the outset of **prostoria**. To us, the design of *Elegance* meant an exploration of the refinement of form, finding the moment in which visual ease and clear sublimated geometry meet. The sofa and armchair frames are relatively thin and somewhat lower, emphasizing the appearance of the cushions and thus underlining comfort. This also helps to lighten the entire volume of the sofa. In contrast to the rigid structure, the seat cushions have slightly rounded edges. The cushions are offered in two alternatives: a softer, visually gentler one, and a harder one that is geometrically more rigid. The visual variability of the set is supplemented by an offering of metal or more classic wooden legs. By combining a series of subtle shifts within a set of accepted rules, we have designed a product characterised by a discreet contemporary elegance and adaptability to different environments.

Sofa *Elegance*, kao i modularna grupa *Classic*, početak je **prostorie**. Dizajn Elegancea za nas je značio istraživanje finoće oblika, traženja trenutka u kojem se susreću vizualna lakoća i jasna, pročišćena geometrija. Okviri sofe i fotelje su relativno tanki i nešto niži, pa se u njenoj pojavnosti više ističu jastuci čime je naglašena udobnost. Također, time je cjelokupni volumen sofe olakšan. Kontrast strogoj konstrukciji su jastuci za sjedenje s blago zaobljenim rubovima. Jastuci se nude u dvije varijante: mekšoj, vizualno nježnijoj, te tvrđoj, koja je geometrijski čvršća. Vizualna varijabilnost grupe upotpunjena je ponudom metalnih ili klasičnijih drvenih nogu. Nizom suptilnih pomaka unutar prihvaćenih pravila dizajnirali smo proizvod koji odlikuje diskretna, suvremena elegancija i prilagodljivost različitim ambijentima.



POLYGON
SMALL TABLE /
LEGS METAL COATED
BLACK, TABLE TOP
FENIX NTM
STOLIĆ / NOGE
METALNE
PLASTIFICIRANE
CRNO, PLOČA
FENIX NTM



4SEATER / FABRIC
HALLINGDAL, LEGS
METAL COATED BLACK
4SJEĆ / TKANINA
HALLINGDAL, NOGE
METALNE
PLASTIFICIRANE
CRNO

POLYGON
ARMCHAIR / FABRIC
HALLINGDAL 65, LEGS
METAL COATED BLACK
FOTELJA / TKANINA
HALLINGDAL 65,
NOGE METALNE
PLASTIFICIRANE
CRNO



POLYGON
SMALL TABLE / LEGS
METAL COATED BLACK,
TABLE TOP FENIX NTM
STOLIC / NOGE METALNE
PLASTIFICIRANE CRNO,
PLOČA FENIX NTM

The *Elegance*, together with the *Classic*, represents the outset of **prostor**. By combining a series of subtle shifts within a set of accepted rules, we have designed a product characterised by a discreet contemporary elegance and adaptability to different environments.

Sofa Elegance, kao i modularna grupa *Classic*, početak je **prostor**. Nizom suptilnih pomaka unutar prihvaćenih pravila dizajnirali smo proizvod koji odlikuje diskretna, suvremena elegancija i prilagodljivost različitim ambijentima.

PROSTOR



ARMCHAIR / FABRIC
HALLINGDAL, LEGS
OAK BLACK
FOTELJA / TKANINA
HALLINGDAL, NOGE
CRNI HRAST



Hotel President, Dubrovnik, Croatia / Photo: Damir Fabijanić



Prostoria Showroom, Zagreb, Croatia / Photo: Domagoj Kunić

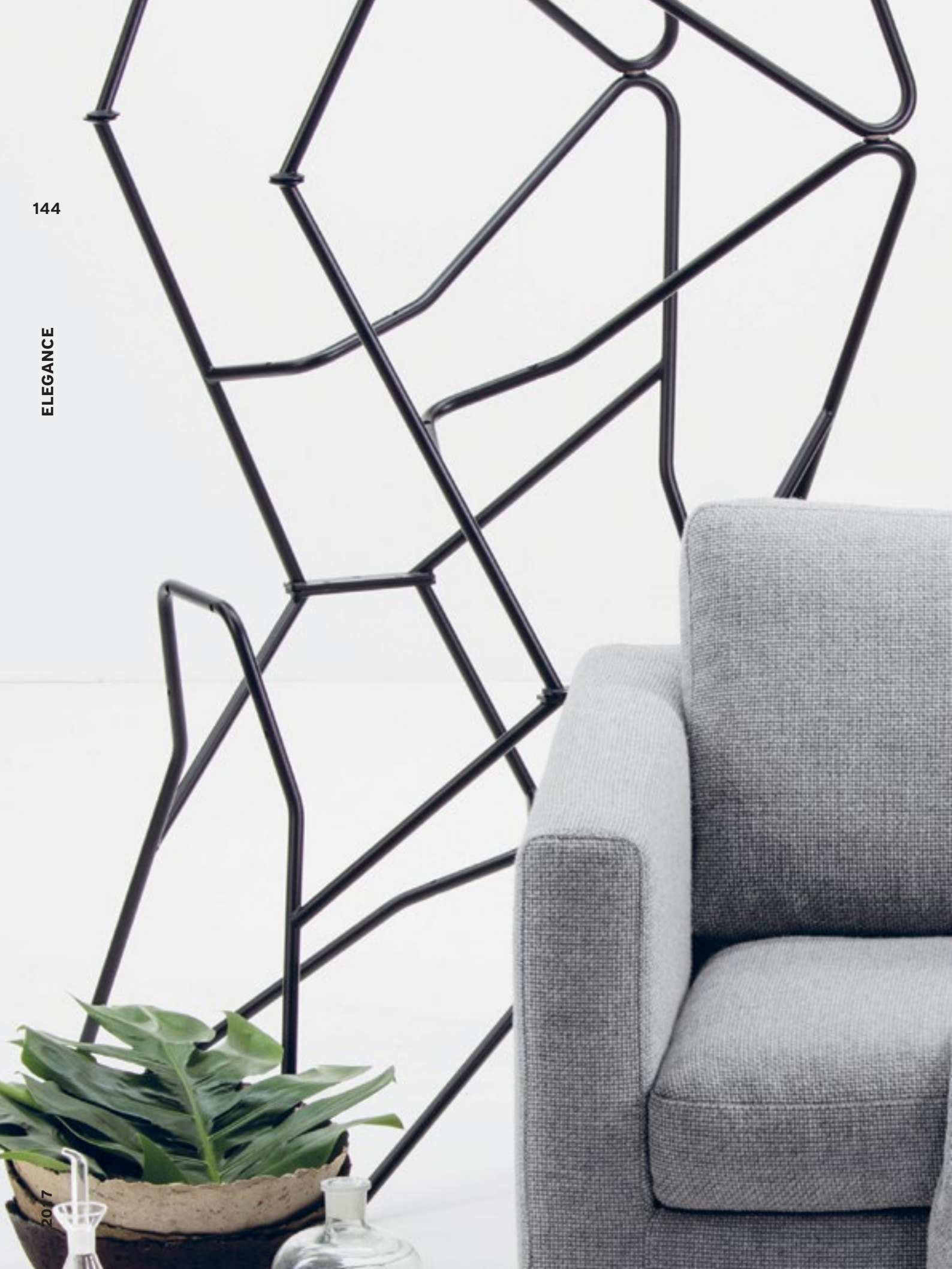

ELEGANCE

ARMCHAIR / FOTELJA

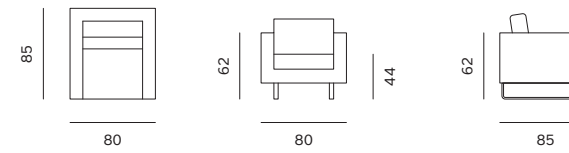

POUF / TABURE

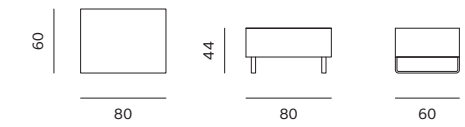

2SEATER / 2SJED

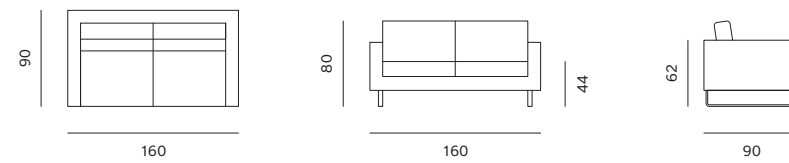

3SEATER / 3SJED

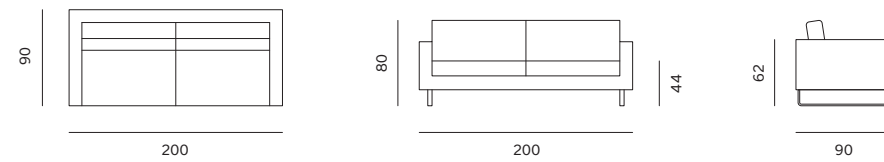

4SEATER / 4SJED

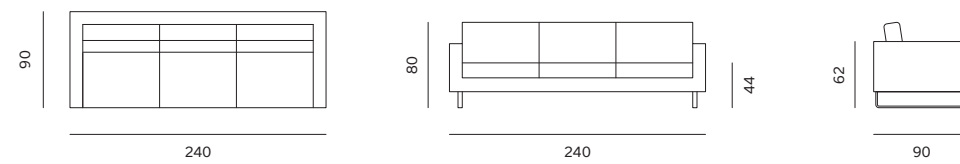

CLASSIC

The timeless design of the *Classic* modular seating set represents, along with the *Elegance* set, the first product line and origin of the company, indicating our fundamental values. Designing the *Classic* was a considerable challenge: how to work out a product that fits into well-established forms, while also creating an added value? The *Classic* set is unintrusive, but its prototypical conception and formal rigidity give it a universal reliable character. It is precisely this universality that allows the soundness of the design and the quality of the materials to speak for themselves. The variety of modules and variations in their width have contributed to the popularity of the set, making it equally suitable for both public and residential spaces.

Izvanvremenski dizajn modularne garniture za sjedenje *Classic*, uz *Elegance* prvi proizvod **prostorie**, ishodište je tvrtke koji je naznačio naše temeljne vrijednosti. Dizajn *Classica* pred nas je postavio znatan izazov: kako osmisliti proizvod koji se uklapa u poznate obrasce, a da se pri tome dosegne dodatna vrijednost. Grupa *Classic* je nenametljiva, no njena prototipska koncepcija i formalna čvrstina pridaju joj univerzalni, pouzdani karakter. Baš ta univerzalnost daje priliku da solidnost izvedbe i kvaliteta materijala govore sami za sebe. Veliki broj modula i varijacije njihovih širina doprinijeli su popularnost grupe koja jednako dobro pristaje i u javne i u stambene prostore.



OBLIQUE
SMALL TABLE /
TABLE TOP
FENIX NTM,
LEGS OAK LIGHT
STOLIĆ / PLOČA
FENIX NTM NOGE
HRAST LIGHT



Castle Sveti Križ Začretje, Croatia / Photo: Domagoj Kunić



ARMCHAIR, POUF /
FABRIC MAINLINE FLAX
FOTELJA, TABURE /
TKANINA MAINLINE
FLAX



The *Classic* set is unintrusive, but its prototypical conception and formal rigidity give it a universal reliable character. It is precisely this universality that allows the soundness of the design and the quality of the materials to speak for themselves.

Grupa *Classic* je nenametljiva, no njena prototipska koncepcija i formalna čvrstina pridaju joj univerzalni, pouzdani karakter. Baš ta univerzalnost daje priliku da solidnost izvedbe i kvaliteta materijala govore sami za sebe.

PROSTORIA



OBLIQUE
SMALL TABLE /
TABLE TOP
FENIX NTM,
LEGS OAK LIGHT
STOLIĆ / PLOČA
FENIX NTM NOGE
HRAST LIGHT

MODULAR COMPOSITION
/ FABRIC MAINLINE FLAX
MODULARNA KOMPOZICIJA
/ TKANINA MAINLINE FLAX

CLASSIC

1SEATER / 1SJED

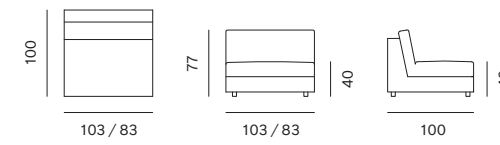

1SEATER + ARMREST (L/R) / 1SJED + RUKONASLON (L/D)

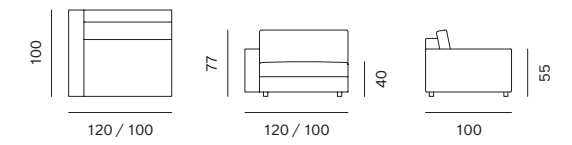

1SEATER + EXTENDED (L/R) / 1SJED + PRODUŽENI (L/D)

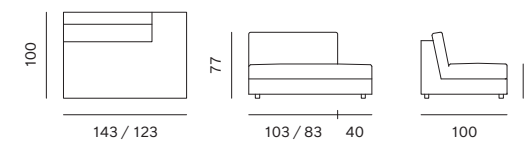

CHAISE LOUNGE (L/R) / PRODUŽENI DIO (L/D)

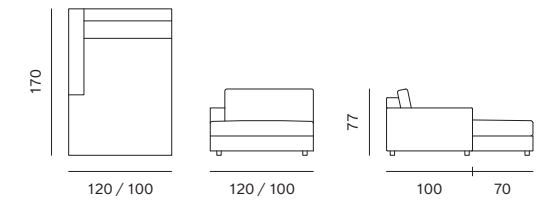

3SEATER / 3SJED, 2,5SEATER / 2,5SJED, 2SEATER / 2SJED

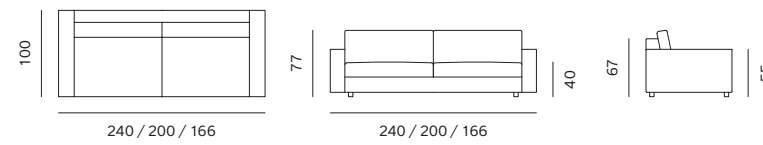

POUF / TABURE

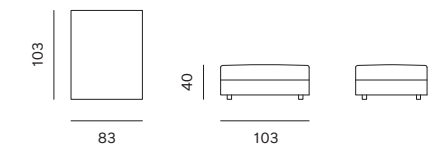

CORNER EXTENDED (L/R) / KUT PRODUŽENI (L/D)

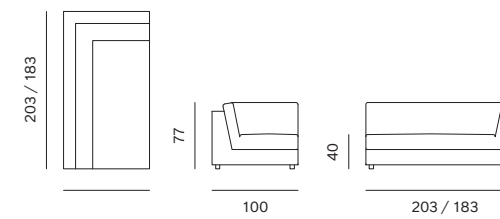

CORNER / KUT

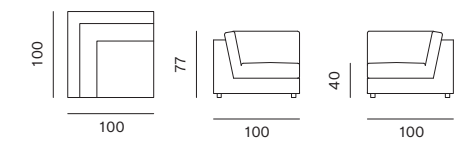
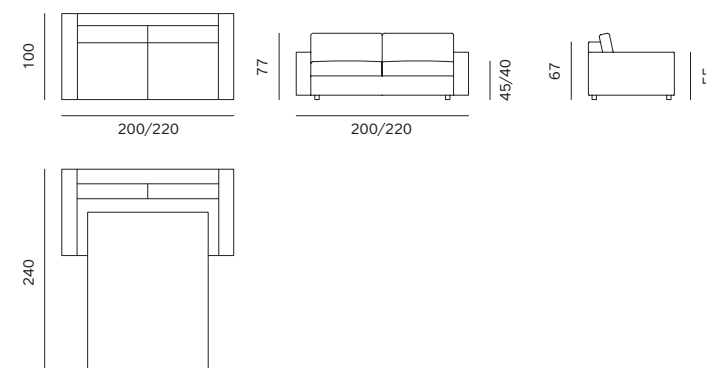
3SEATER + MATTRESS / 3SJED + MADRAC
2,5SEATER + MATTRESS / 2,5SJED + MADRAC

ARMCHAIR / FOTELJA

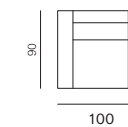

CONVERT



While designing the *Convert*, my intention was to take a step forward from the standard model of modular furniture. We have been thinking about an open system that can accommodate multiple changes in form, spatial arrangement and function, which is interactive and developing together with the user at the same time stimulating his or her imagination. New situations, equally suitable for homes and public spaces, are created by freely combining or upgrading the basic elements – seating modules, fixed or movable backrests and storage platforms. The modules are discrete in shape yet their open system concept and the use of various materials make every group unique and distinctive.

Prilikom projektiranja *Converta* želio sam otići korak dalje od standardnog modela modularnog namještaja. Razmišljali smo o otvorenom sustavu koji je sposoban za višestruke promjene forme, prostornog rasporeda i funkcije, koji je interaktivan, koji se razvija zajedno s korisnikom i potiče njegovu ili njezinu imaginaciju. Slobodnim kombiniranjem ili dograđivanjem seta osnovnih elemenata – sjedećih modula, fiksnih i pomičnih naslona i platoa za odlaganje - stvaraju se uvijek nove situacije koje jednako dobro odgovaraju i domovima i javnim prostorima. Moduli su diskretno oblikovani, ali koncepcija otvorenog sustava i primjena različitih materijala čini svaku grupu jedinstvenom i posebnom.



We have been thinking about an open system that can accommodate multiple changes in form, spatial arrangement and function, which is interactive and developing together with the user at the same time stimulating his or her imagination.

Razmišljali smo o otvorenom sustavu koji je sposoban za višestruke promjene forme, prostornog rasporeda i funkcije, koji je interaktivan, koji se razvija zajedno s korisnikom i potiče njegovu ili njezinu imaginaciju.

SIMON MORASI PIPERČIĆ





3SEATER /
LEATHER
ELMOSOFT
3SJED / KOŽA
ELMOSOFT

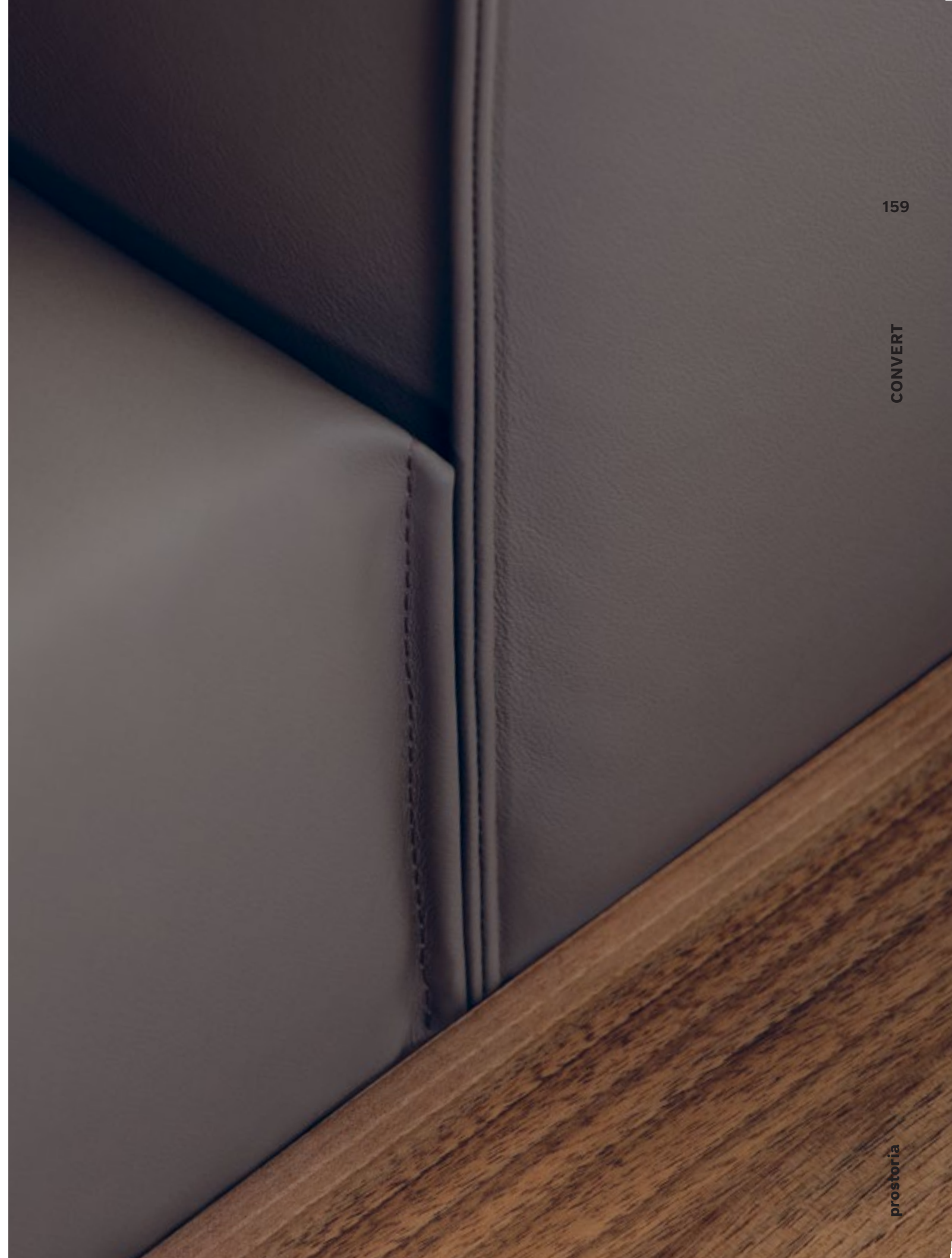



CONVERT

COMPONENTS / KOMPONENTE

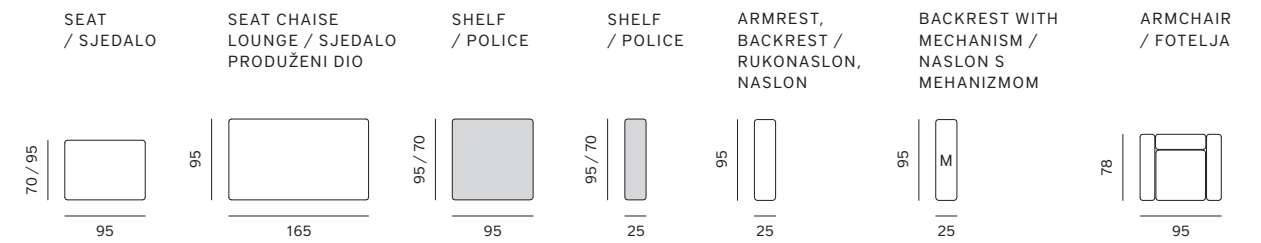

COMPOSITION EXAMPLES / PRIMJERI KOMPOZICIJA

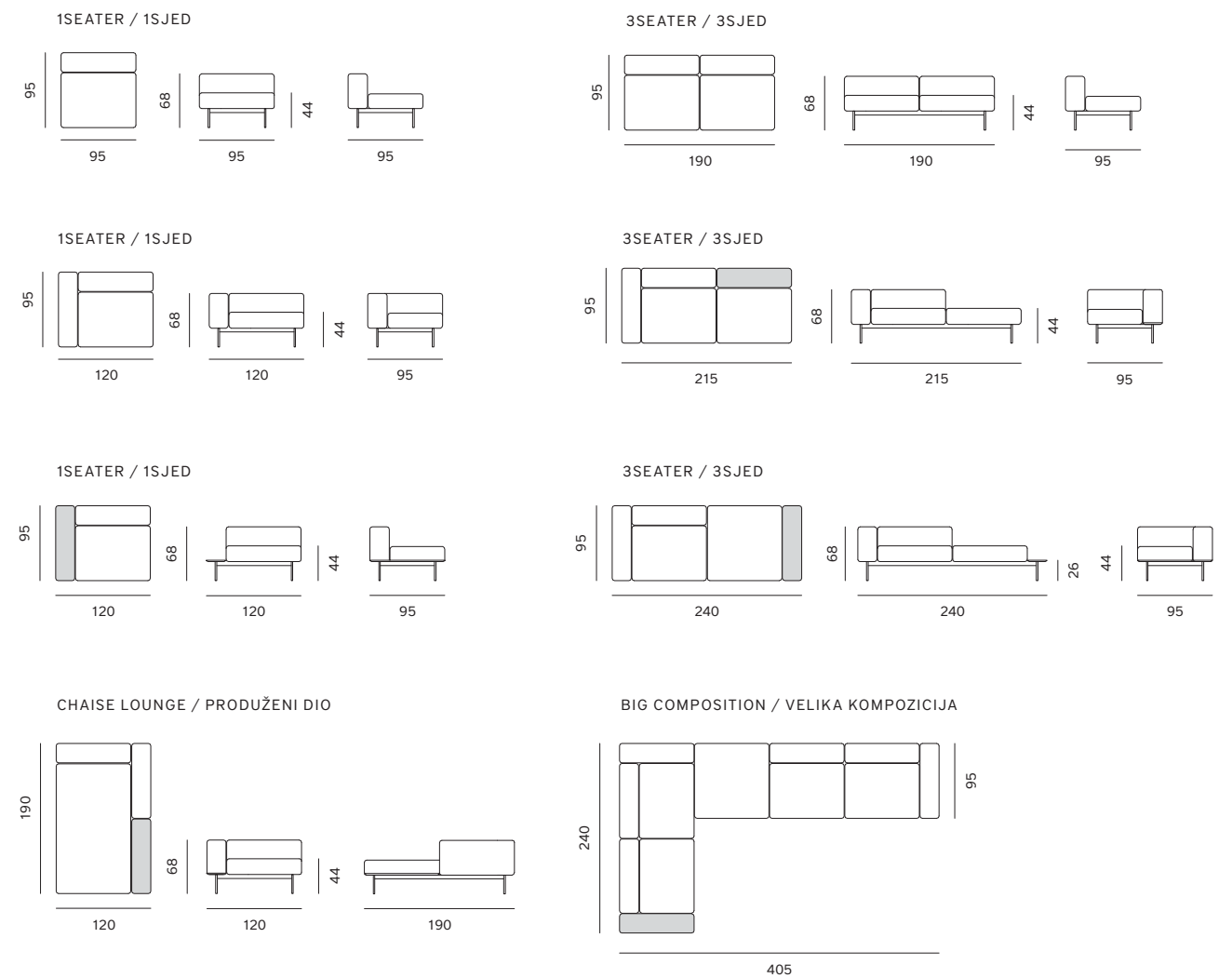

SEGMENT



When designing the *Segment*, we were interested in finding a solution for the hierarchy in combining elements for modular upholstered furniture. In the case of any conventional modular sofa, there is always one element that 'dominates' and directs the system of combinations. In the case of the *Segment*, borders on the main element used for the seat, backrest and armrests are sloped at a 45-degree angle. This allows free combining of the system on all three axes. The main reference for this design was the seven-segment character display used on earlier digital clocks. That is also how the sofa got its name. With this concept, the user has the opportunity to compose various and even unconventional compositions in space. Countless combinations of the base and backrest form a system that is functional and open for designing diverse interior landscapes.

U osmišljavanju *Segmenta* zanimalo nas je rješavanje problema hijerarhije sastavljanja elemenata modularnog ojastućenog namještaja. Kod konvencionalne modularne sofe uvijek jedan element "dominira" i usmjerava kombinacije slaganja sustava. Rubovi glavnog elementa *Segmenta*, kojim su riješeni sjedalo, naslon i rukonaslon, skošeni su pod kutom od 45 stupnjeva. Time se omogućava slobodno kombiniranje slaganja sustava u sve tri osi. Kao referenca za dizajn poslužilo nam je oblikovanje znamenki 7-segmentnih tipografija s ranih digitalnih satova, iz čega je proizašao i sam naziv. Koncept *Segmenta* pruža korisniku priliku sastavljanja raznolikih, pa i nekonvencionalnih kompozicija u prostoru. Bezbrojne kombinacije baza i naslona zahvalan su otvoreni sustav za projektiranje različitih interijerskih pejzaža.





'SNAKE' MODULAR
 COMPOSITION / FABRIC TOPIA,
 LEGS METAL COATED 5003
 MODULARNA KOMPOZICIJA
 'ZMIJA' / TKANINA TOPIA, NOGE
 METAL PLASTIFICIRANI 5003





Business centre Spectator Solis, Zagreb, Croatia / Photo: Domagoj Kunić



ARMCHAIR / FABRIC
DIVINA MD, LEGS
METAL COATED 9003
FOTELJA / TKANINA
DIVINA MD, NOGE METAL
PLASTICIFIRANI 9003

In the case of the *Segment*, borders on the main element used for the seat, backrest and armrests are sloped at a 45-degree angle. This allows free combining of the system on all three axes.

Rubovi glavnog elementa *Segmenta*, kojim su riješeni sjedalo, naslon i rukonaslon, skošeni su pod kutom od 45 stupnjeva. Time se omogućava slobodno kombiniranje slaganja sustava u sve tri osi.

NUMEN/FOR USE

MODULAR COMPOSITION
WITH PLATFORM / FABRIC
DIVINA MD, LEGS METAL
COATED 9003
MODULARNA KOMPOZICIJA
S PODESTOM / TKANINA
DIVINA MD, NOGE METAL
PLASTIFICIRANI 9003



SMALL TABLE /
TABLE TOP MDF,
LEGS METAL
COATED 9003
STOLIĆ / PLOČA
MDF, NOGE METAL
PLASTIFICIRANI
9003



PLATFORM /
MDF LACQUERED
PODEST / MDF
LAKIRANI



Radisson Blue
Hotel, Helsinki,
Finland / Project:
Sisustusarkkitehdit
Fyra Oy / Photo:
Eeli Saaristo



Castle Sveti Križ, Croatia / Photo: Domagoj Kunić

MODULAR
COMPOSITION
WITH PLATFORM /
FABRIC TOPIA
MODULARNA
KOMPOZICIJA S
PODESTOM /
TKANINA TOPIA

SEGMENT

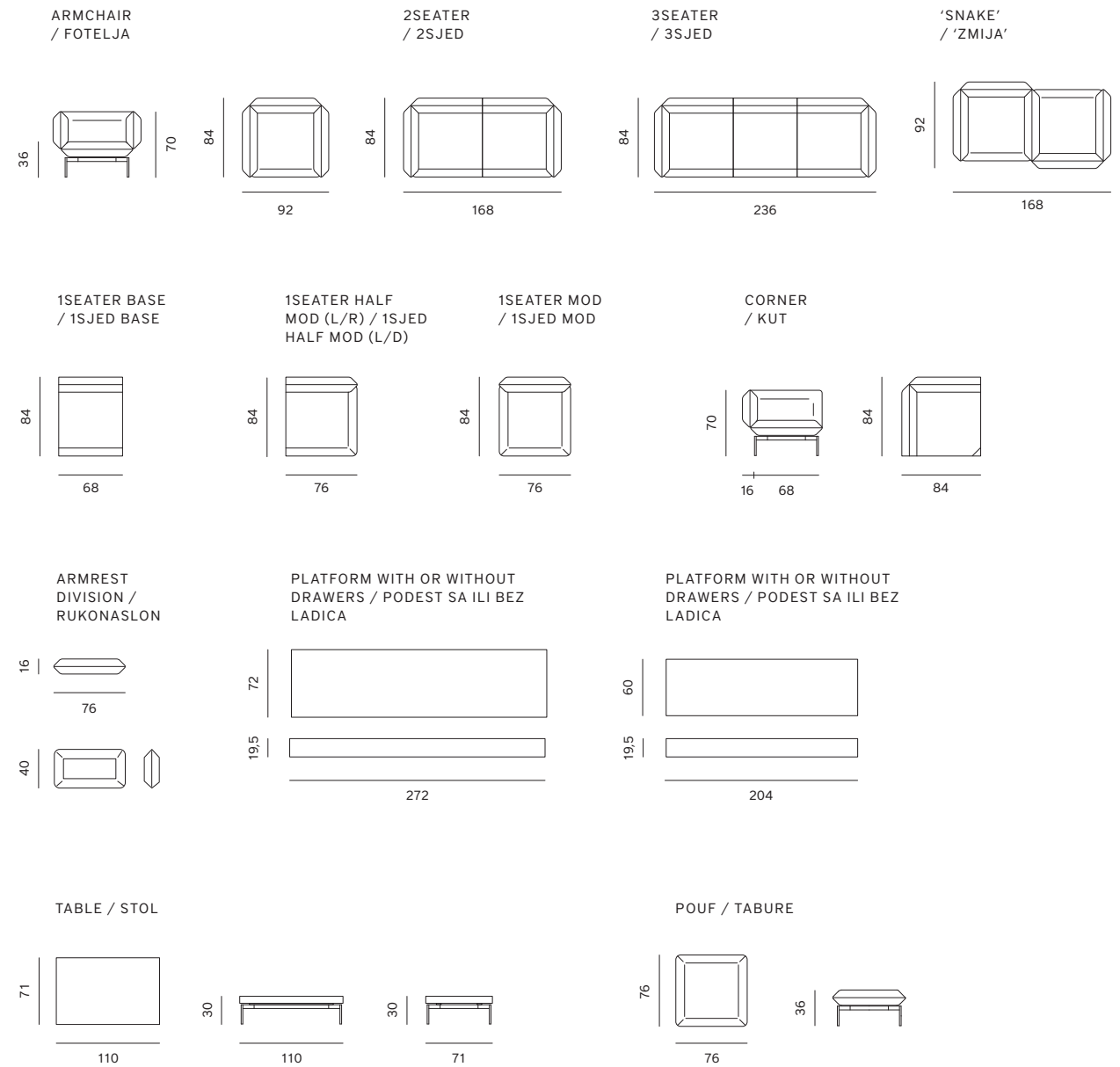

SEAM



DESIGN: BÖTTCHER HENSSLER KAYSER

The design of the *Seam* sofa is the result of our efforts to integrate elegant form and the purity of a single volume for comfortable sitting, without cushions that are often reminiscent of residential settings. The extremely deep armrest and backrest sink in an expressive curve towards the seat, which represents an ergonomic solution and is at the same time the trademark of the sofa's identity. The geometry of the curvature is accentuated with the stitches on the covers. The sofa's volume is integrated and continues along the height of the armrest and backrest. Despite its rigid geometry reduced to elementary gestures, the sofa nevertheless invokes various organic associations, such as a fan or seashell. It is perhaps precisely this ambivalence that has ensured its acclaim and widespread use in public places.

Dizajn sofe *Seam* rezultat je našeg nastojanja da objedinimo elegantnu formu s čistoćom monovolumena za udobno sjedenje, bez jastuka koji često asociraju na stambene ambijente. Izrazito duboki rukonaslon i naslon u izražajnom luku poniru prema sjedalu što je istovremeno i ergonomski kvalitetno rješenje i nositelj identiteta sofe. Geometrije zaobljenja naglašene su šavovima na presvlakama. Volumen sofe objedinjen je kontinuiranom visinom rukonaslona i naslona. Iako je geometrija sofe stabilna, svedena na elementarne geste, ona ipak izaziva različite organske asocijacije poput lepeze ili školjke. Možda joj je baš ta ambivalentnost osigurala uspjeh široke primjene u javnim prostorima.

3SEATER / FABRIC
STEELCUT TRIO 2,
LEGS METAL COATED
3SJED / TKANINA
STEELCUT TRIO 2,
NOGE METAL
PLASTIFICIRANI

SEAM



FRAME 5
SMALL TABLE / FRAME
METAL COATED, TABLE
TOP TEMPERED GLASS
STOLIĆ / KONSTRUKCIJA
METAL PLASTIFICIRANI,
PLOČA KALJENO STAKLO



3SEATER / FABRIC
 STEELCUT TRIO 2,
 LEGS METAL COATED
 3S.JED / TKANINA
 STEELCUT TRIO 2,
 NOGE METAL
 PLASTIFICIRANI

The design of the *Seam* sofa is the result of our efforts to integrate elegant form and the purity of a single volume for comfortable sitting, without cushions that are often reminiscent of residential settings.

Dizajn sofe *Seam* rezultat je našeg nastojanja da objedinimo elegantnu formu s čistoćom monovolumena za udobno sjedenje, bez jastuka koji često asociraju na stambene ambijente.

BÖTTCHER HENSSLER KAYSER



Seven Bridges Genomics offices, New Belgrade, Serbia / Project: Antipod studio / Photo: Relja Ivanić



SEAM

2SEATER / 2SJED

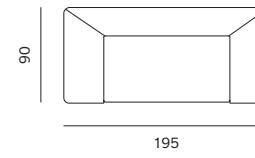

3SEATER / 3SJED

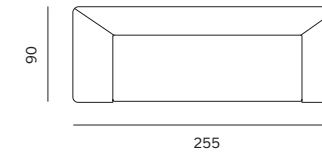

CORNER EXTENDED (L/R)
/ KUT PRODUZENI (L/D)

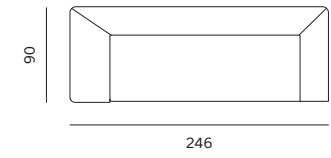

END UNIT (L/R)
/ ZAVRSETAK (L/D)

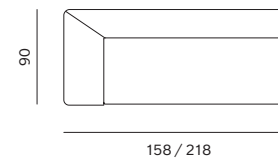

CHAISE LOUNGE (L/R)
/ PRODUZENI DIO (L/D)

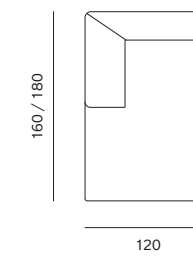

POUF
/ TABURE

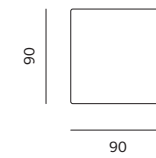

INTERIOR INNOVATION AWARD 2015 WINNER
 IF DESIGN AWARD 2015 WINNER
 GOLDEN KEY AWARD 2016 WINNER

FRAME



The elementary forms of the *Frame* coffee table collection can have different characteristics depending on their colour, material or position in the space. Table tops with compact core or multi-coloured tempered glass are sunk into white or black thin metal frames. Grouped together or standing individually, the *Frame* coffee tables have a very wide range of uses and visual effects. Functioning as the central low table positioned next to a seating set or a coffee table used for putting things down, highlighted or discretely set in space, the *Frame* contributes to the use of space and the ambience in a variety of ways.

FRAME 01
SMALL TABLE / STOLIĆ

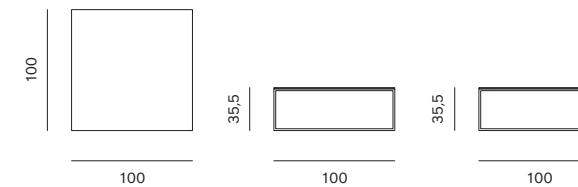

FRAME 02
SMALL TABLE / STOLIĆ

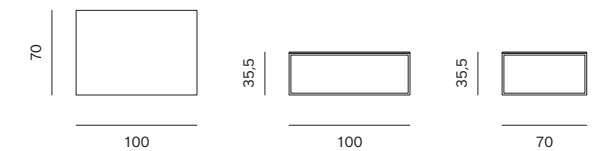

FRAME 03
SMALL TABLE / STOLIĆ

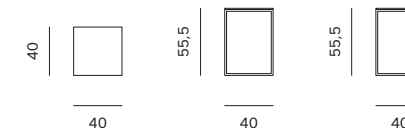

FRAME 04
SMALL TABLE / STOLIĆ

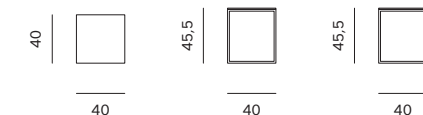

FRAME 05
SMALL TABLE / STOLIĆ

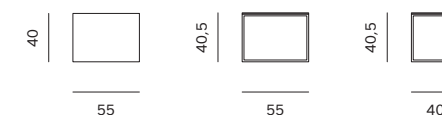

FRAME 06
SMALL TABLE / STOLIĆ

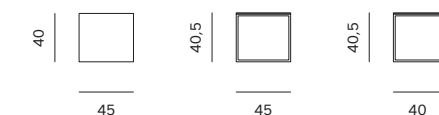

Elementarne forme stolića *Frame* poprimaju različite karaktere ovisno o boji, materijalu i smještaju u prostoru. U tanke metalne bijele ili crne okvire upuštene su plohe s kompaktnom jezgrom ili satiniranim kaljenim staklom u bojama. Samostalno ili u skupini, stolići *Frame* širokog su raspona primjena i vizualnih učinaka. Od funkcije glavnog stola u blagovaonici do stolića za priručno odlaganje, od akcenta u prostoru do diskretnog objekta, *Frame* na različite načine doprinosi načinima korištenja prostora i atmosferi ambijenata.

COMBO

From its very beginnings, **prostor** explores themes of flexibility and transformability. The *Combo* set is our first step forward in this field – the three models, with or without the extended part, combine different functions: sitting, lying, playing and leisure... The unfolding procedure is simple, and the set includes a storage area. *Combo* is conceived as an extremely simply designed platform that can support different living scenarios, whereas its playfulness is complemented by the supplementary feather-stuffed soft cushions.

Od samih početaka **prostor** istražuje teme fleksibilnosti i transformabilnosti. Garnitura *Combo* je naš prvi iskorak u to područje gdje se u tri modela, sa i bez produženog dijela, kombiniraju različite funkcije: sjedenja, ležanja, igre, dokolice... Postupak rasklapanja je lagan, a garnitura uključuje i spremišni prostor. *Combo* je osmišljen kao krajnje jednostavno oblikovana platforma spremna podržati različite životne scenarije, a njenu razigranost dopunjuju dodatni mekani jastuci punjeni perjem.

2,5SEATER + EXT. /
FABRIC HALLINGDAL 65
2,5SJED S PRODUŽENIM
DIJELOM / TKANINA
HALLINGDAL 65



FRAME 5
SMALL TABLE / FRAME
METAL COATED, TABLE
TOP TEMPERED GLASS
STOLIĆ / KONSTRUKCIJA
METAL PLASTIFICIRANI,
PLOČA KALJENO STAKLO

Combo is conceived as an extremely simply designed platform that can support different living scenarios, whereas its playfulness is complemented by the supplementary feather-stuffed soft cushions.

Combo je osmišljen kao krajnje jednostavno oblikovana platforma spremna podržati različite životne scenarije, a njenu razigranost dopunjuju dodatni mekani jastuci punjeni perjem.

PROSTORIA





BoShop, Aarhus, Denmark



Prostoria Showroom, Sv Križ Začretje, Croatia / Photo: Vanja Šolin



COMBO

2,5SEATER + EXTENDED (L/R) / 2,5SJED + PRODUŽENI (L/D)

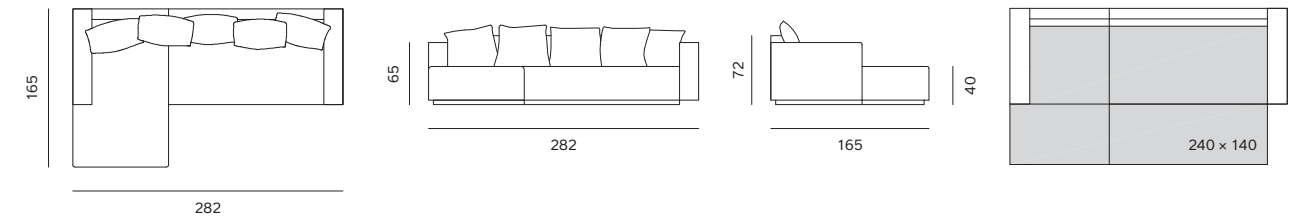

2SEATER + EXTENDED (L/R) / 2SJED + PRODUŽENI (L/D)

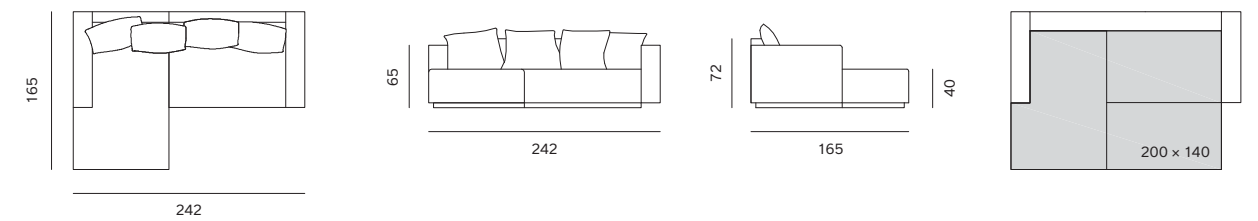

3SEATER SOFA / 3SJED SOFA

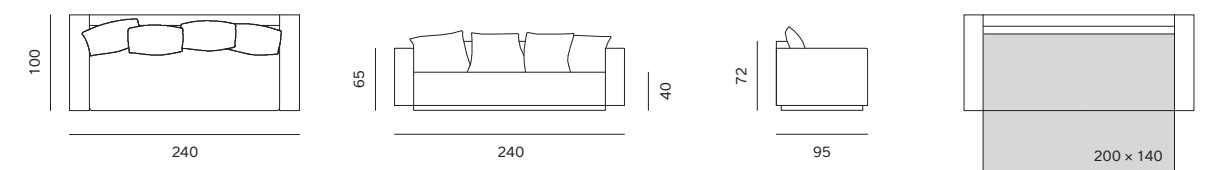

CHAISE LOUNGE (L/R) / PRODUŽENI DIO (L/D)

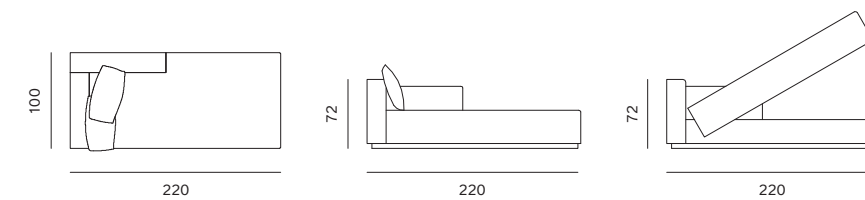

UP-LIFT



While designing the *Up-lift* armchair and sofa, our concept was to transform them into a bed with a single action. This action gives the impression of an elegantly orchestrated and rhythmical movement. By pulling the backrest forward, the side ends of circular armrests lean on the floor and serve as the eccentric rotation point around which the sofa easily opens into a functional bed. The attractive and contemporary form of the accentuated shape becomes pragmatically justified in almost surprising transformation and interaction with the user. The idea is original and unprecedented; this often tiresome action of unfolding an armchair or a sofa has been turned into a game that delights with its ingenuity. Such a solution rules out complicated mechanisms and constructions, at the same time maintaining a high level of comfortable sitting and lying. A very rare typology of an unfolding armchair is available with one and a half or double seats.

Fotelju i sofu *Up-lift* koncipirali smo tako da se one samo jednom radnjom transformiraju u ležaj. Ta radnja djeluje poput elegantno orkestriranoga, ritmičnog plesnog pokreta. Povlačenjem naslona prema naprijed, krajevi bočnih zaobljenih rukonaslona oslanjaju se na pod i služe kao ekscentrična točka rotacije oko koje se čitava fotelja/sofa jednostavno rasklapa u funkcionalni ležaj. Dopadljiva, suvremena forma naglašeno zaobljene konture svoje pragmatično objašnjene dobiva u gotovo iznenađujućoj transformaciji i interakciji s korisnikom. Zamisao je izvorna, bez prethodnika, a inače često zamorna radnja razvlačenja fotelje ili sofe u ležaj pretvorena je u igru koja uveseljava svojom domišljatošću. Rješenje eliminira složene mehanizme i konstrukcije, a udobnost i ležanja i sjedenja su na visokoj razini. Rijetka tipologija rasklopive fotelje dostupna je i u varijantama jedne i pol, te dvije širine sjedenja.



ARMCHAIR /
FABRIC REMIX
FOTELJA /
TKANINA
REMIX

While designing the *Up-lift* armchair and sofa, our concept was to transform them into a bed with a single action. This action gives the impression of an elegantly orchestrated and rhythmical movement.

Fotelju i sofu *Up-lift* koncipirali smo tako da se one samo jednom radnjom transformiraju u ležaj. Ta radnja djeluje poput elegantno orkestriranoga, ritmičnog plesnog pokreta.

REDESIGN

2SEATER /
FABRIC ERA
2SJED /
TKANINA
ERA



ARMCHAIR /
FABRIC REMIX
FOTELJA /
TKANINA
REMIX



OBLIQUE
SMALL TABLE /
TABLE TOP
FENIX NTM,
LEGS OAK LIGHT
STOLIĆ / PLOČA
FENIX NTM NOGE
HRAST LIGTH





Hotel Navis Opatija, Croatia
 Project: Idis Turato
 Photo: Bosnić+Dorotić





UP-LIFT



CLOSED ARMCHAIR
/ ZATVORENA FOTELJA

CLOSED 1,5SEATER
/ ZATVORENI 1,5SJED

CLOSED 2SEATER
/ ZATVORENI 2SJED

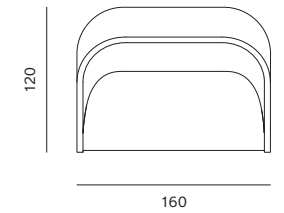
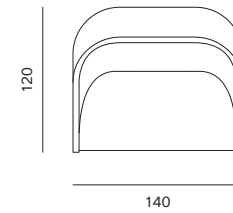

OPENED ARMCHAIR
/ OTVORENA FOTELJA

OPENED 1,5SEATER
/ OTVORENI 1,5SJED

OPENED 2SEATER
/ OTVORENI 2SJED

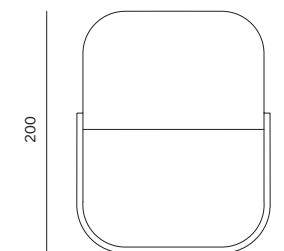
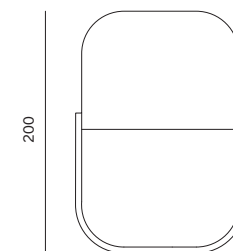
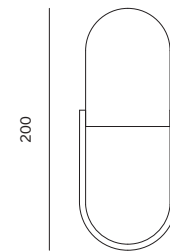

INTERIOR INNOVATION AWARD 2014 WINNER
GERMAN DESIGN AWARD 2015 SPECIAL MENTION

REVOLVE



Our design of the sofa that transforms into the bed is based on our previous experience when we realized that complicated mechanisms do not really function in the long run. That is why we focused on the search for the simplest unfolding method possible. We have created a system with which the backrest rotates at 180 degrees around the seat and becomes part of the bed. The open bed form is symmetrical and fits well independently in the space. The form of this position is equally balanced as the position of a folded sofa, which is often not the case with folding furniture. Just like with mono-functional mattresses, the quality of relaxation is equally distributed along the width owing to the construction made from cold foam and applied on both blocks. **prostor**'s expertise in cold foam technology was a very valuable contribution in the process of reaching that functional goal. We highlighted this basic, almost banal unfolding method with a leather handle so that the user accepts the way the sofa functions almost instinctively.

Naš dizajn za sofau koja se pretvara u krevet baziran je na prijašnjim iskustvima, gdje smo shvatili da komplicirani mehanizmi dugoročno ne funkcioniraju dobro. Zato smo se fokusirali na traženje najjednostavnijeg mogućeg načina rasklapanja. Osmislili smo sustav u kojem se naslon jednostavno rotira oko sjedala za 180 stupnjeva i postaje dio ležaja. Rastvorena forma ležaja je simetrična i dobro samostalno stoji u prostoru. Ta forma jednako je skladna kao i sklopljena pozicija sofe, što često nije slučaj kod rasklopivog namještaja. Kvaliteta ležanja je, kao u monofunkcionalnim madracima, jednaka u cijeloj širini zahvaljujući konstrukciji od hladne pjene primijenjenoj u oba bloka. U postizanju tog funkcionalnog cilja ekspertiza **prostor** u tehnologiji hladne pjene bila nam je od velike pomoći. Bazični, gotovo banalni sustav otvaranja apostrofirali smo kožnom omčom ručke te korisnik praktički instinktivno usvaja funkcioniranje sofe.



We have created a system with which the backrest rotates at 180 degrees around the seat and becomes part of the bed. The open bed form is symmetrical and fits well independently in the space.

Osmislili smo sustav u kojem se naslon jednostavno rotira oko sjedala za 180 stupnjeva i postaje dio ležaja. Rastvorena forma ležaja je simetrična i dobro samostalno stoji u prostoru.

NUMEN/FOR USE
BOROVNJAK & BRATOVIĆ

POLYGON
SMALL TABLE
/ LEGS METAL
COATED BLACK,
TABLE TOP
FENIX NTM
STOLIĆ / NOGE
METALNE
PLASTIFICIRANE
CRNO, PLOČA
FENIX NTM





Studio Scenography, Zagreb, Croatia / Photo: Domagoj Kunić



REVOLVE



3SEATER SOFA / 3SJED

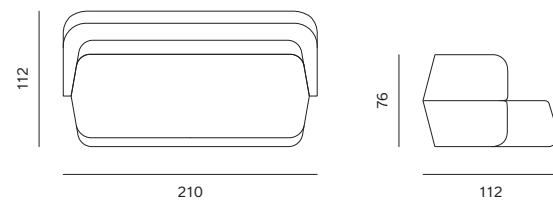

SOFABED / LEŽAJ

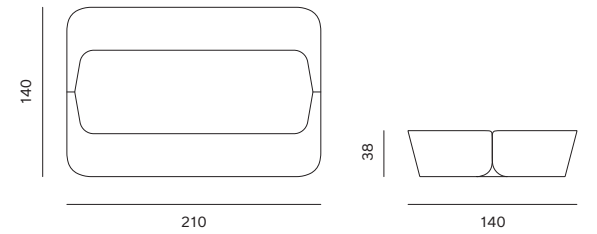

POUF / TABURE

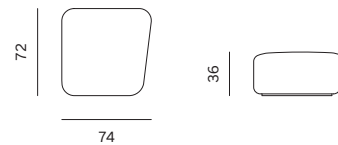

reddot award
winner 2012

RED DOT DESIGN AWARD 2012 WINNER

PIL-Low



While designing the *Pil-low*, we focused our research on the most effective transformation from a sofa into a bed. This transformation functions like a simple spatial puzzle. In the closed position, between the volume of the seat and the backrest, there is a hard triangular pillow that adds to the quality of sitting. The sofa opens when entirely lifted forward and rotated around the sub-construction, hiding space for storing bed linen. The backrest is then rotated backwards and the emerging gap is used for storing the pillow. With this system, all elements of the sofa are put to use as an expanded sleeping platform. Opening and closing of the sofa is optimized without a single superfluous element: all elements fall into their place. This ingenious *transformer* is marked with precise geometry and remarkable presence with playful colours of stitching and legs.

Prilikom dizajna *Pil-lowa* istraživanje smo usmjerili prema što učinkovitijoj transformaciji iz sofe u ležaj. Ta transformacija funkcionira poput jednostavnog prostornog *puzzlea*. U zatvorenom položaju, između volumena sjedala i naslona postavljen je čvrsti trokutasti jastuk koji doprinosi kvaliteti sjedenja. Sofa se rasklapa tako da se čitava podigne prema naprijed rotirajući oko potkonstrukcije, koja skriva prostor za posteljinu. Zatim se naslon zarotira unatrag, a u nastali se procjep ubacuje jastuk. Takvim sustavom iskorišteni su svi elementi sofe kao proširena ploha za spavanje. Radnje sklapanja i rasklapanja su optimizirane, i nema niti jednog suvišnog elementa: sve sjeda na svoje mjesto. Domišljati *transformer* obilježava precizna geometrija, no njegova pojavnost razigrana je bojama štepova i nogu.



3SEATER / FABRIC
CANVAS, LEGS
METAL COATED
3SJED / TKANINA
CANVAS, NOGE METAL
PLASTIFICIRANI



**Opening and closing
of the sofa is optimized
without a single
superfluous element:
all elements fall
into their place.**

Radnje sklapanja i rasklapanja
su optimizirane, i nema niti
jednog suvišnog elementa: sve
sjeda na svoje mjesto.

REDESIGN

3SEATER / FABRIC
CANVAS, LEGS
METAL COATED
3SJED / TKANINA
CANVAS, NOGE METAL
PLASTIFICIRANI



Private apartment New York, USA
Project: Studio Esnal / Photo: Miguel
de Guzman / Imagen Subliminal



TKANINA
/ FABRIC
CLARA 2



PIL-LOW



3SEATER SOFA / 3SJED

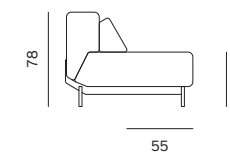
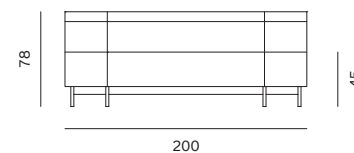
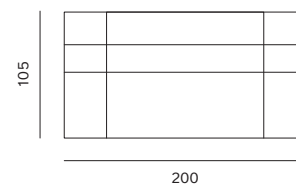

SOFA BED / LEŽAJ

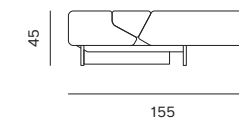
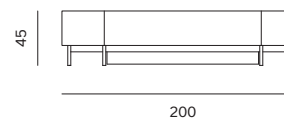
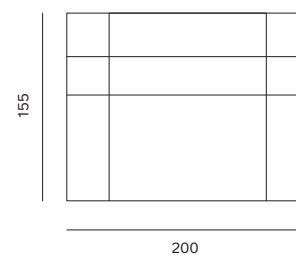

SIMETRIA



Being composed of a single element, i.e. massive oak sticks, *Simetria* was a challenging task for us, implying the quest for an expressive impression combined with the functionality derived from minimum means. The coat stand is symmetrical on both axes but its appearance changes depending on the perspective: from a serene mathematical sculpture to a vibrant and almost disorganized composition. *Simetria* is very practical: it is delivered in a flat pack, easy to assemble and has seamless joints. A relatively prosaic typology has been transposed into the pleasure of designing.

Sastavljena od samo jednog elementa, masivnih hrastovih štapova, *Simetria* je za mene bila izazov traženja ekspresivnog dojma i funkcionalnosti izvedenih iz minimalnih sredstava. Vješalica je simetrična i po horizontalnoj i po vertikalnoj osi, no njena slika mijenja se ovisno o perspektivi: od smirene matematičke skulpture do vibrantne, skoro razbarušene kompozicije. *Simetria* je vrlo praktična: isporučuje se u "flat packu", spojevi su nevidljivi i jednostavna je za sastavljanje. Razmjerno prozaična tipologija prevedena je u dizajnerski užitak.

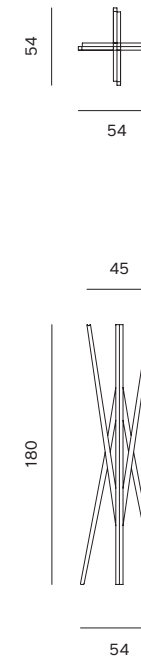

NUMEN/FOR USE



Numen/ForUse (Sven Jonke, Christoph Katzler, Nikola Radeljković) is a Croatian-Austrian design collective working in the fields of scenography, industrial and spatial design and conceptual art. Under the banner ForUse they designed for Cappellini, ClassiCon, Desalto, Interlubke, Magis, MDF Italia, Moroso and Zanotta. Numen/ForUse are the only Croatian contemporary

product designers whose works are regularly represented in global anthologies of contemporary design.

Numen/ForUse (Sven Jonke, Christoph Katzler, Nikola Radeljković) je hrvatsko-austrijski dizajnerski kolektiv koji radi na području scenografije, industrijskog dizajna, dizajna interijera i konceptualne umjetnosti. Osim za prostoriu, dizajnirali su namještaj za Cappellini, ClassiCon, Desalto, Interlubke, Magis, MDF Italia, Moroso i Zanottu. Numen/ForUse su jedini suvremeni hrvatski dizajneri čiji su radovi redovito uvršteni u antologije suvremenog dizajna.

SANJA KNEZOVIĆ



Sanja Knezović is primarily an architect who heads her own architectural studio, which specializes in private houses and smaller commercial buildings. She has transferred the experience gained from designing furniture units for interiors onto designing upholstered furniture for **prostor**, her first project in the field of product design.

Sanja Knezović je primarno arhitektica koja vodi vlastiti arhitektonski studio projektirajući privatne kuće i manje poslovne objekte. Svoje iskustvo dizajniranja komadnog namještaja za interijere pretočila je u dizajn ojaštuenog namještaja za tvrtku **prostor**, njezin prvi projekt na području produkt dizajna.

GRUPA



Members of *Grupa* are designers Filip Despot, Ivana Pavić and Tihana Taraba. For a number of years, they have been collaborating with Croatian and foreign furniture producers and since 2010 they have started developing their own brand named the *Grupa products*, which are distributed on the international and European markets. They have been exhibiting on

domestic and international juried exhibits and their works were published in important international and Croatian publications. They have also been awarded many prizes.

Grupu čine dizajneri Filip Despot, Ivana Pavić i Tihana Taraba. Niz godina surađuju s hrvatskim i inozemnim proizvođačima namještaja, a 2010. započinju s razvojem vlastitog branda Grupa products čije proizvode distribuiraju na svjetsko i europsko tržište. Izlažu na domaćim i međunarodnim selektivnim izložbama, a radovi su objavljivani u značajnim međunarodnim i hrvatskim publikacijama. Dobitnici su niza nagrada i priznanja.

REDESIGN



Redesign is a multidisciplinary design studio focusing on the development of concepts for new products and technological innovations. Owing to their knowledge of various technological fields, they have realized a wide range of projects, from the design for recycled cardboard shelves to a sophisticated device used in rehabilitation, testing and training of the knee joint. In their work, the team

strives for comprehensive solutions that represent the synthesis of all disciplines in the sphere of design.

Redesign je multidisciplinarni dizajn studio usmjeren na razvoj koncepata novih proizvoda i tehnoloških inovacija. Zahvaljujući dobrom poznavanju različitih područja tehnologije do sada su realizirali širok raspon projekata - od dizajna recikliranih kartonskih polica do sofisticiranog uređaja za rehabilitaciju, testiranje i trening zgloba koljena. U svom radu teže cjelovitim rješenjima koja predstavljaju sintezu svih disciplina u sferi dizajna, a zahvaljujući poznavanju različitih područja tehnologije do sada su realizirali širok raspon projekata - od dizajna namještaja do sofisticiranog uređaja...

SIMON MORASI PIPERČIĆ



Established in 2013, Simon Morasi Piperčić is a Zagreb-based design office working on various projects ranging from product, furniture, spatial design and installation to art direction and strategic consultancy. The office has been granted with some of the most highly considered awards - The German Design Award in 2017, twice Red Dot in 2013 and 2015 and Interior Innovation Award in 2015. In 2014, they were a part of the team that designed the Croatian pavilion at the Venice

architecture biennale. Their work was published in several renowned magazines (*Dezeen*, *Domus*, *Frame*, *Designboom* etc.) and exhibited worldwide.

Osnovan 2013. godine ured Simon Morasi Piperčić, sa sjedištem u Zagrebu, djeluje na različitim projektima od produkt dizajna, unutarnjeg uređenja i instalacija do art direkcije i strateškog savjetovanja. Ured je osvojio neke od najprestižnijih nagrada kao što su German Design Award 2017 za stolicu Rhomb, 2013 i 2015 Red Dot nagradu i Interior Innovation Award 2015. godine. 2014. godine ured je sudjelovao u projektu izrade hrvatskog paviljona na arhitektonskoj bienalnoj izložbi u Veneciji. Radovi ureda Simon Morasi Piperčić objavljivani u su u prestižnim časopisima (*Dezeen*, *Domus*, *Frame*, i *Designboom*) i izlagani su na izložbama diljem svijeta.

BÖTTCHER HENSSLER KAYSER



Moritz Böttcher and Sören Henssler founded their Berlin based design studio in 2007. In 2013 the designer Nikolaus Kayser joined the team. Since 2014 the trio is working under the studio name Böttcher Henssler Kayser in the fields of consumer product, furniture and lighting design with companies such as ANTA, Böwer, Mater, Normann Copenhagen, Scantex, Schönbuch, Vertigo Bird and Zero. The designers were honoured with a number of distinctions like iF and red dot

design awards, the prestigious red dot „best of the best“ and the Interior Innovation Award 2015 for their sofa Seam produced by **prostor**

Moritz Böttcher i Sören Henssler osnovali su svoj Studio Böttcher+Henssler 2007. godine u Berlinu. 2013. godine dizajner Nikolaus Kayser pridružio se timu. Kao trio djeluju pod imenom Studio Böttcher Henssler Kayser u području produkt dizajna, dizajna namještaja i rasvjete. U njihove klijente ubrajaju se njemačke i međunarodne tvrtke kao što su ANTA, Böwer, Mater, Normann Copenhagen, Scantex, Schönbuch, Vertigo Bird i Zero. Dizajneri su počašćeni velikim brojem nagrada među kojima i Red Dot nagrade za dizajn, prestižna Red Dot nagrada "best of the best" te Interior Innovation Award 2015 - pobjednik, za sofou Seam u produkciji **prostor**.



prostoría Ltd
Pustodol Začreški 19g
49223 Sveti Križ Začretje
Croatia

t +385 49 200 555
f +385 49 200 556
e info@prostoría.eu
www.prostoría.eu

All inquiries international markets:
t +385 49 200 555
f +385 49 200 556
e export@prostoría.eu

prostoría d.o.o.
Pustodol Začreški 19g
49223 Sveti Križ Začretje
Hrvatska

t +385 49 200 555
f +385 49 200 556
e info@prostoría.hr
www.prostoría.hr

Veleprodaja i izvoz:
t +385 49 200 555
f +385 49 200 556
e export@prostoría.hr

PUBLISHER
prostoría Ltd

TEXT
Maroje Mrduljaš
designers
prostoría

ART DIRECTION / SET DESIGN
/ **GRAPHIC DESIGN / LAYOUT**
Bilić_Müller Studio

LAYOUT / CO-WORKER
Negra Nigoević

COVER ILLUSTRATIONS
Danijel Srdarev

TEXTILE INSTALLATION
Ivana Zozoli, Bilić_Müller Studio

PHOTOGRAPHY
Vanja Šolin (Proces 15)

PHOTOGRAPHY PROCESSING
Iron&ja

TRANSLATION
Mirna Herman Baletić

PROOFREADING
Maja Trinajstić

PRINTED BY
Printera, Zagreb

NAKLADNIK
prostoría d.o.o.

TEKSTOVI
Maroje Mrduljaš
dizajneri
prostoría

ART DIREKCIJA / SCENOGRAFIJA
/ **GRAFIČKO OBLIKOVANJE / PRIJELOM**
Bilić_Müller Studio

PRIJELOM / SURADNIK
Negra Nigoević

ILUSTRACIJE NA NASLOVNICI
Danijel Srdarev

TEKSTILNE INSTALACIJE
Ivana Zozoli, Bilić_Müller Studio

FOTOGRAFIJA
Vanja Šolin (Proces 15)

OBRADA FOTOGRAFIJA
Iron&ja

PRIJEVOD
Mirna Herman Baletić

LEKTURA
Maja Trinajstić

TISAK
Printera, Zagreb

PROPS / REKVIZITI
Marina Badurina
bilić_müller studio
Lidia Boševski, Atelier Owl
Grupa Products
Havranek+Lugonja
Oaza
Danijel Srdarev
Sanja Mrša Vukman

This brochure is for informational purposes only and it is made in accordance with the information at the time of printing. Deviations of ±3 cm in product dimensions are possible. We are not responsible for any printing errors, subsequent product changes or image fidelity. We kindly ask you to contact our authorised sales outlets for all queries regarding product characteristics and appearance, and any additional or new information required for reaching a final purchase decision.

All rights reserved.
© 2017 prostoría Ltd

Brošura je informativnog karaktera i izrađena prema važećim podacima u trenutku tiskanja. Moguća su odstupanja u dimenzijama proizvoda ±3 cm. Ne odgovaramo za greške nastale u tisku, naknadne promjene proizvoda ili vjernost prikaza fotografije. Molimo Vas da se za sve detaljne karakteristike i izgled proizvoda, dodatne ili novije informacije potrebne za donošenje konačne odluke o kupnji obratite u naša ovlaštena prodajna mjesta.

Sva prava pridržana.
© 2017 prostoría d.o.o.

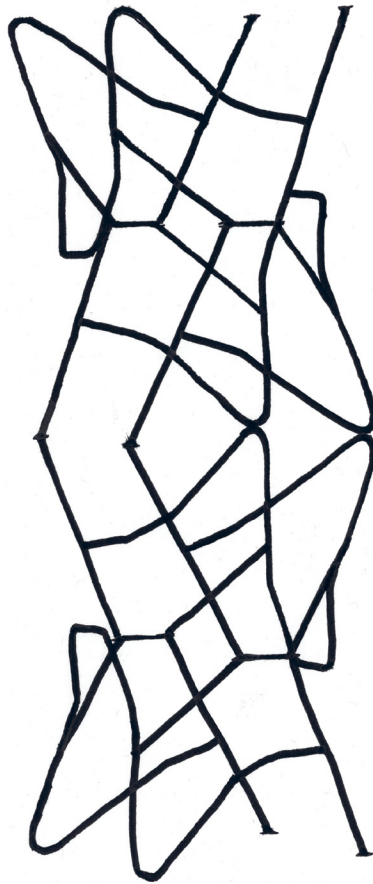

www.prostoria.eu